

DOUGLAS STREET GARAGE PLANNING STUDY

prepared for:
UNIVERSITY OF ARKANSAS | FAYETTEVILLE
FACILITIES MANAGEMENT PLANNING AND DESIGN

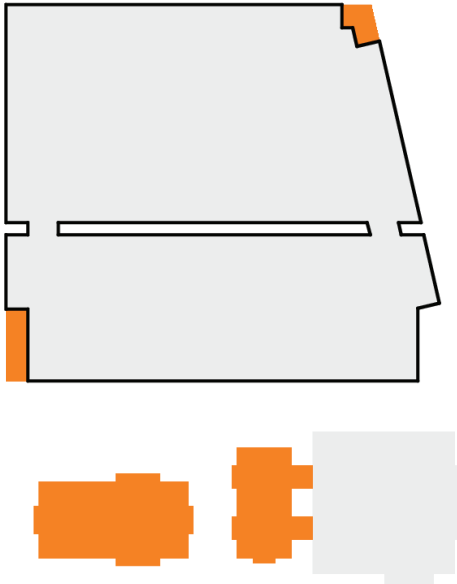

10.9.2017
v3.0

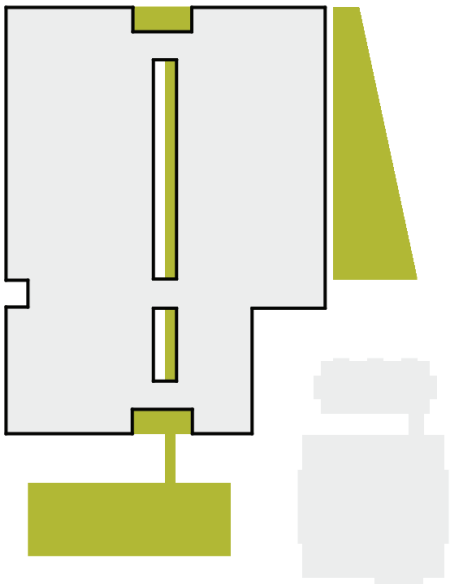
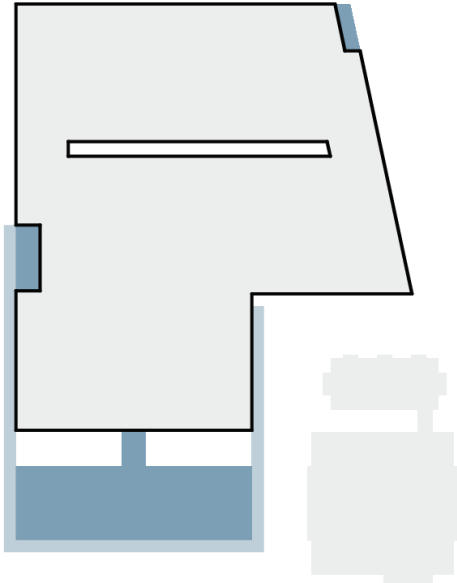

PROJECT TEAM



UNIVERSITY OF ARKANSAS
521 Razorback Rd.
Fayetteville, Arkansas 72701
P: (479) 575-6601
uark.edu

MIKE JOHNSON, AVC for FAMA
DAN CLAIRMONT, Dir. Engr & Const., CHENG
JAMES EZELL, Dir. Risk & Property Mgmt
COLLEEN BRINEY, AVC for Business Affairs
GARY SMITH, Dir. Parking and Transit
JAY HUNEYCUTT, Dir. Planning and Design, CPO
TODD FURGASON, Senior Campus Planner
HEIKO MUELLER, AIA, Campus Planner



POLK STANLEY WILCOX ARCHITECTS
509 W. Spring Street, Suite 150
Fayetteville, Arkansas 72701
P: (479) 444-0473
polkstanleywilcox.com

MARK HERRMANN, AIA, Principal
JACK REILLY, AIA
ANNE WORLEY, Associate AIA



2525 Bay Area Boulevard, Suite 400
Houston, Texas 77058
P: (281) 280-0068
walkerparking.com

WALKER PARKING CONSULTANTS
CASEY WAGNER, Executive Vice President/COO
JEREMY ROCHA, Parking Consultant III



215 Park Avenue South
New York City, New York 10003
P: (212) 242-2490
nelsonnygaard.com

NELSON\NYGAARD
JASON SHRIEBER, AICP, Principal
MERITXELL FONT, Senior Associate





TABLE OF CONTENTS

- INTRODUCTION 2
- ANALYSIS..... 4
 - Topography..... 5
 - Scull Creek 6
- EXPLORATION 8
 - Option A 10
 - Option B 14
 - Option C 18
 - Matrix 22
- RECOMMENDATIONS..... 24
 - Option A.1..... 25
 - Option B.1 33
 - Option C.1..... 41
- RESULTS 52

CLEVELAND STREET

GARLAND AVENUE PARKING GARAGE
1,500 spaces

DOUGLAS STREET

DOUGLAS STREET PARKING GARAGE
proposed site

MAPLE STREET

STADIUM DRIVE PARKING GARAGE
586 spaces

CAMPUS CORE

DICKSON STREET

RAZORBACK ROAD

STADIUM DRIVE

MCLLOY AVENUE

HARMON AVENUE PARKING GARAGE
2,149 spaces

MEADOW STREET PARKING GARAGE
216 spaces

HARMON AVENUE

UNIVERSITY AVENUE

WHITHAM AVENUE

GREGG AVENUE

ARKANSAS AVENUE



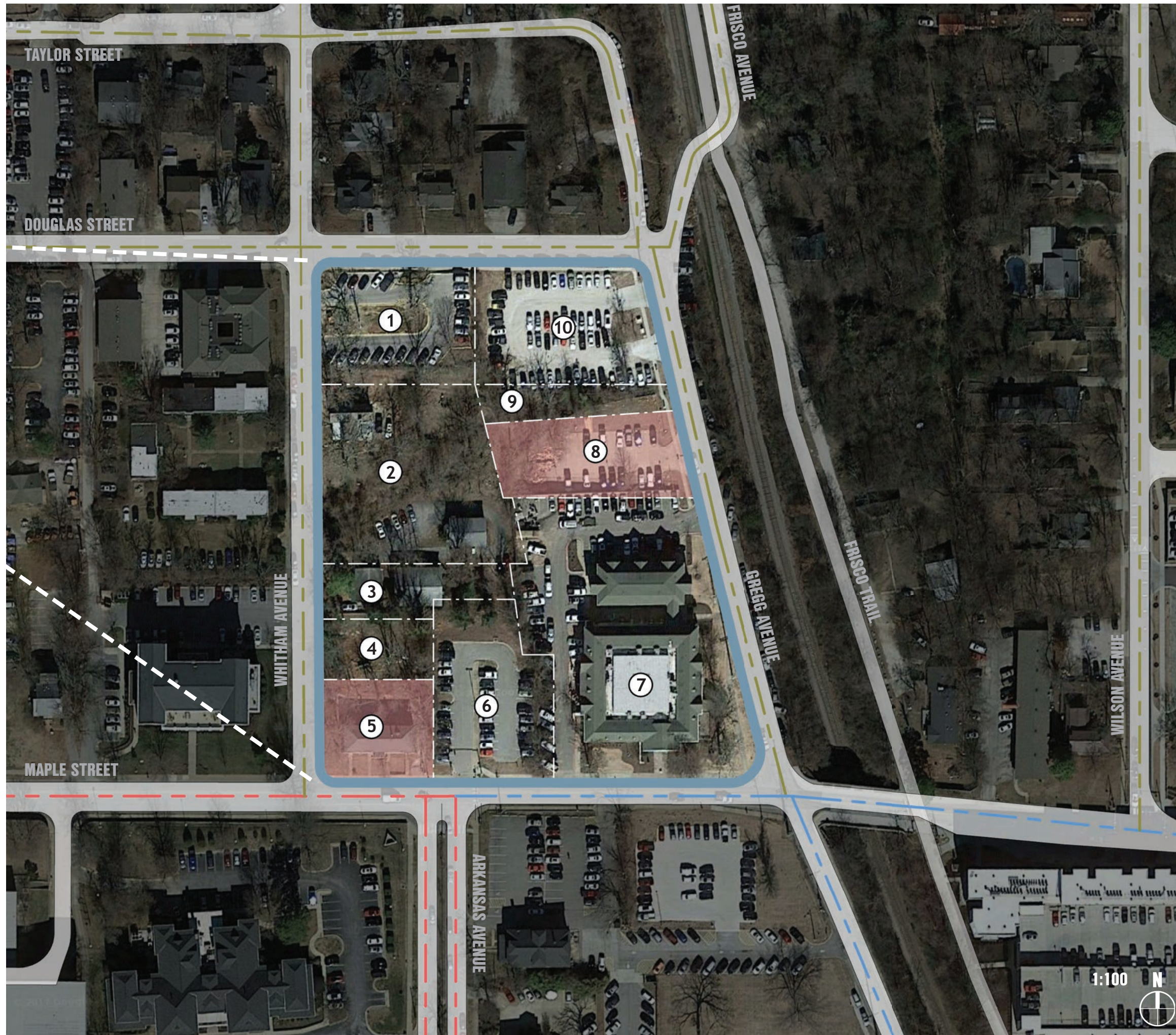

INTRODUCTION

As the University of Arkansas continues to grow, the ever-growing need for additional parking follows right behind. With parking demand again heavily outweighing supply, this study is tasked with how to best utilize the potential site on the NE corner of the campus, successfully weaving a multi-level parking garage into the overall fabric of the campus. Fronted on all sides by Fayetteville city streets, the majority of the proposed properties are already owned by the University. Project limits within the property are clearly defined as “edge of curb” with one exception – The Sigma Chi fraternity has occupied the SE corner for years and this study should assume that they are to remain in some capacity. Various options for Sigma Chi will be addressed throughout the study that address the Sigma Chi Annex to the north and the current vehicular loop with access to Gregg and Maple. Proposed solutions will also need to account for the 179 surface parking spaces that are currently spread over the 4.88-acre collection of parcels.

There will be a number of determinants that affect the final design of the proposed facility, but our team has been tasked with proposing three distinct options that address two dominant needs:

1. Increase parking capacity for the NE corner of campus. This will in turn reduce parking demand for other areas of campus.
2. Reduce vehicular traffic flow along Maple Street. This will result in a safer pedestrian experience along the NE corner of the campus.

ROAD TYPE KEY

- LOCAL
- URBAN
- INSTITUTIONAL

PROPERTY INFORMATION

1. SURFACE PARKING (23 SPACES) - UA OWNED	.47 ACRE
2. RENTAL PROPERTY - UA OWNED	.80 ACRE
3. RENTAL PROPERTY - UA OWNED	.224 ACRE
4. LOT - UA OWNED	.166 ACRE
5. RENTAL PROPERTY - PRIVATELY OWNED	.28 ACRE
6. SURFACE PARKING (31 SPACES) - UA OWNED	.487 ACRE
7. SIGMA CHI FRATERNITY AND SURFACE PARKING (46 SPACES) - UA OWNED	1.46 ACRE
8. SURFACE PARKING (24 SPACES) - PRIVATELY OWNED	.383 ACRE
9. LOT WITH UTILITY EASEMENT - UA OWNED	.144 ACRE
10. SURFACE PARKING (55 SPACES) - UA OWNED	.542 ACRE

TOTAL PARKING SPACES: 179
 TOTAL ACREAGE: 4.88 ACRES



1. ARKANSAS AND MISSOURI RAILROAD



2. SIGMA CHI FRATERNITY HOUSE



3. STONE HOUSE



4. ALPHA OMICRON PI SORORITY HOUSE



5. COURTS AT WHITHAM APARTMENT HOUSES



6. MULTI-FAMILY RESIDENTIAL



7. SINGLE FAMILY RESIDENTIAL



8. FRISCO TRAIL

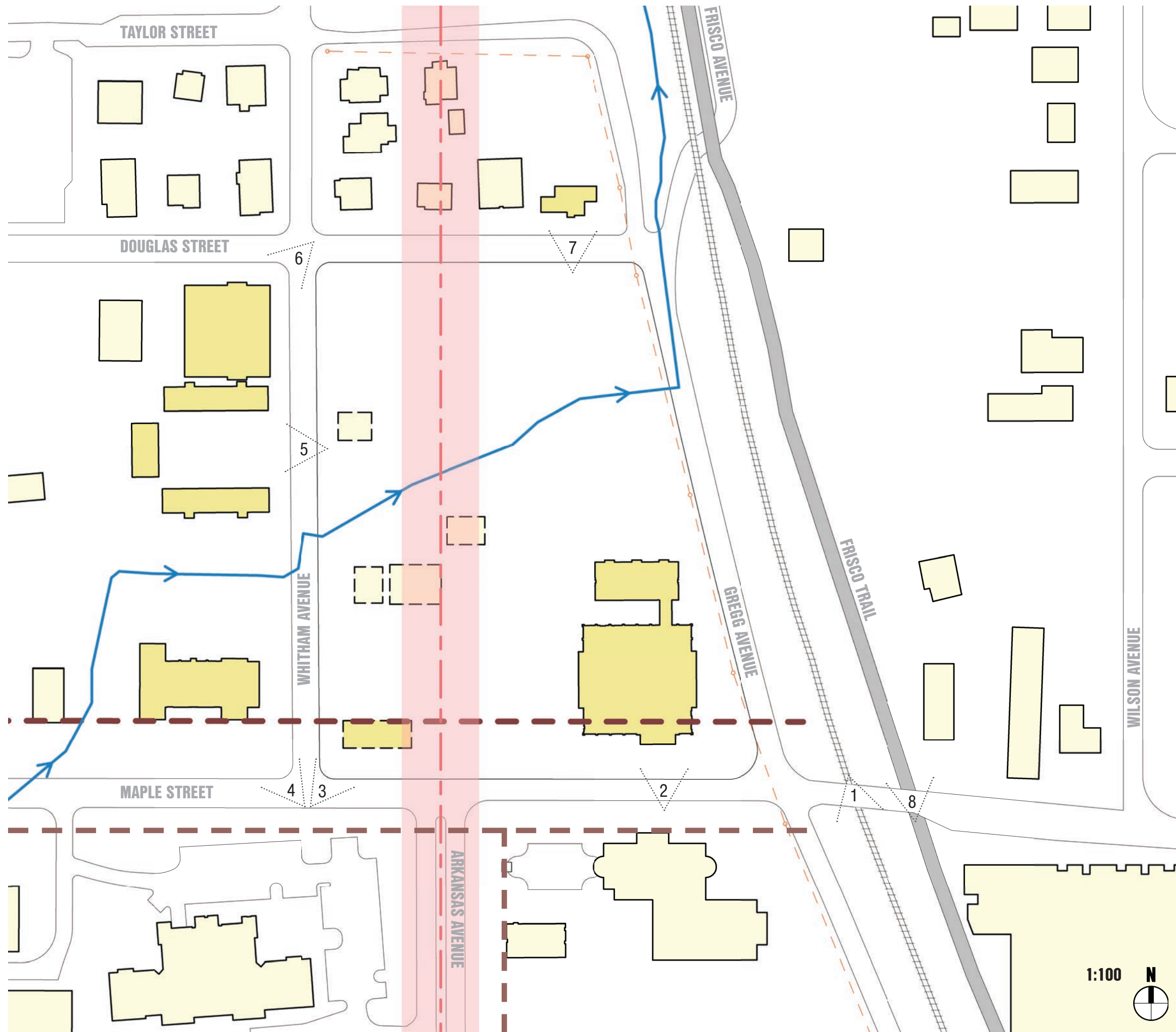

ANALYSIS

- - - PRIMARY AXIS ALONG ARKANSAS AVENUE
- - - PREFERRED FRONTAGE LINE
- SCULL CREEK
- TO BE DEMOLISHED
- - - OVERHEAD ELECTRIC TO REMAIN

A thorough analysis of the proposed site and the neighboring properties quickly identifies a distinct variation in the surrounding context. A successful parking garage for this site will find a way to meld with four distinct streetscapes.

The southern edge of the proposed site borders Maple Street (commonly referred to as Sorority Row), and more importantly the prominent intersection of Maple Street and Arkansas Avenue. One of the primary drivers for this project will be to protect the viewshed from a southern Arkansas Avenue approach as well as east/west traffic along Maple. For this reason, all options will be presented with an appropriate solution to the Maple street frontage. While the presence of the garage cannot be masked in entirety, a building other than a parking structure should be used to front Maple and serve as a complimenting neighbor to the surrounding Greek context. When placing a building along Maple, the frontage line established by the UofA Master Plan will be observed in order to maintain a consistent campus “boulevard” along Sorority Row.

Whitham Avenue starts with the Alpha Omicron Pi Sorority house and then transitions to apartment houses protected from the street and multifamily housing that offers a good example of scale for future development.

Gregg Avenue is interesting in that it runs parallel to both the Arkansas Missouri Railroad as well as the Frisco Trail. The tracks and the trail are both hidden from view by heavy plant growth along the eastern edge of Gregg. There is a continuous run of high-voltage overhead electrical power that runs down the western edge of Gregg and is within our project limits. These lines are not slated for relocation and must be maintained under any proposed project.

From a scale and proportion standpoint, Douglas Avenue frontage is perhaps the most difficult to deal with. The proposed garage will tower over a row of single-family residences as the north end of the proposed site is at the lowest elevation and will result in the tallest portion of the deck above grade.

TOPOGRAPHY

When utilized properly, a substantial change in grade can offer several benefits to a structured parking facility. Our proposed site has approximately 55 feet of grade change dropping from SW to NE with the high end being the corner of Maple and Whitham. The low end is at the intersection Gregg and Douglas and provides immediate access to the Frisco Trail and a proposed Gregg Avenue extension to the north. When identifying areas that will work well for vehicular entry/exit points, anything higher than 8% slope should be discouraged. For a multi-level deck, access points at higher levels are preferred - Entering as high as possible and preferably leading to a ramp that goes up an additional level helps distribute the parking load and moves patrons immediately towards the upper levels that can often be overlooked. Multiple access points at different levels also help disperse parking and subsequently reduce traffic.

While a thorough traffic analysis will determine the direction of traffic on Whitham, special attention should be given to the relatively flat area along the northern section of the street. This area communicates very well with Level 3 of all of our proposed options. Coupled with direct access to an upward moving ramp, we are providing quick access to the upper levels of the deck immediately off the street.

The grade along Douglas is not favorable until you reach the eastern approach of the intersection with Gregg. Whether the access point is on Gregg or Douglas, the NE corner of the site provides a clean approach to Level 1 of the garage.

The majority of Gregg Avenue is at or near the maximum slope recommended for vehicular entry/exit. Proposed level elevations in the following garage options offer access points at Level 2 and possibly Level 3 along this portion of Gregg.

Any proposed building fronting Maple should take advantage of residing on the high point on the site, and serve as a prominent landmark as the terminus to Arkansas Avenue. The steep grade change at this corner should also allow for a walk-out condition to the north (level below) as the street facing level will reside slightly higher than our base elevation of 1400'-0".

Likely the greatest benefit to our site as it pertains to a parking garage is that we will be able to cut into the site allowing the perceived height of the structure to feel much lower as it faces campus to the south. All options presented start with the assumption that full excavation would occur. This means that if Level 1 roughly aligns with Gregg and Douglas that the entire footprint of Level 1 would be cut all the way south into the site. This can be expensive to construct and retain, as well as add additional requirements for mechanical ventilation. For this reason, a few of the preferred options (see Recommendations) propose partial excavation of the lower levels allowing the garage to step with the natural change in topography. While this limited excavation does have a significant impact on overall parking counts, it can also reduce the cost per parking spot by up to 10%.

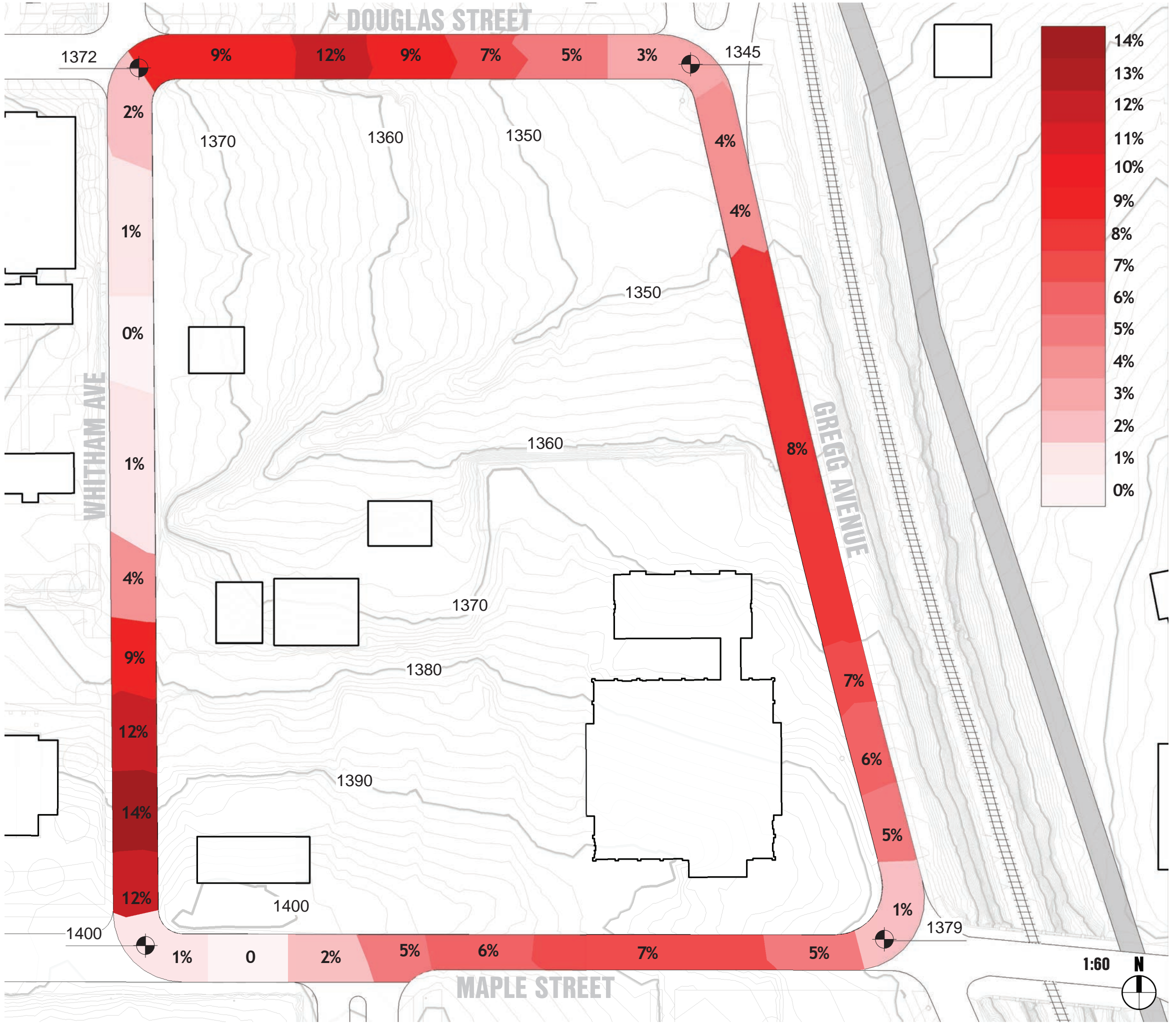

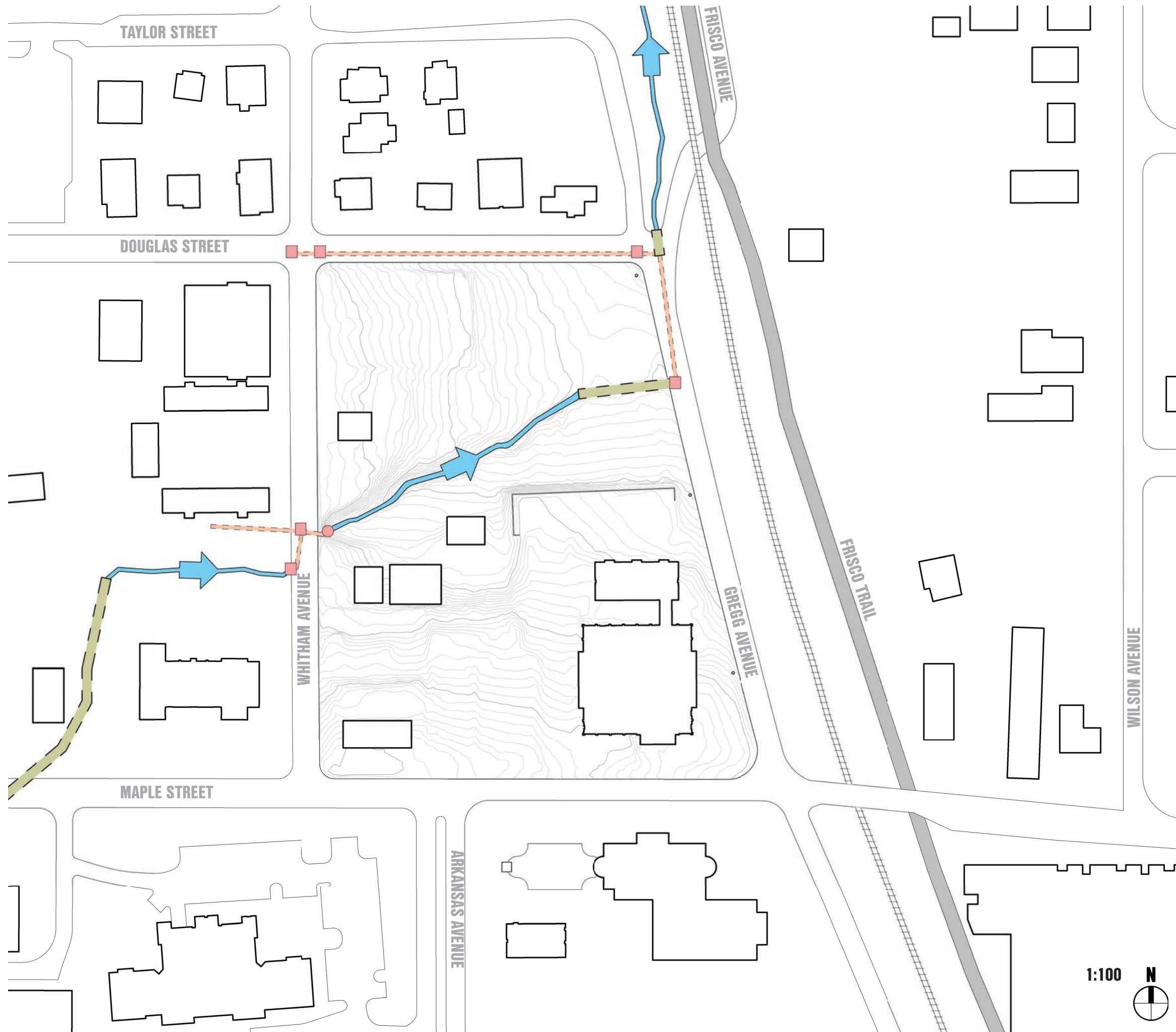

SCULL CREEK

- STORM WATER OUTLET (shown in picture below)
- CURB OR GRATE INLET
- UNDERGROUND STORM PIPE
- UNDERGROUND STORM CULVERT
- OPEN AIR STORM WATER

Scull Creek belongs to the Illinois River Watershed and originates in the higher elevations of Fayetteville. After a confluence with Mud Creek and then Clear Creek, Scull Creek ultimately finds its way into the Illinois River. In the past small creeks and waterways such as this were often dismissed and rerouted as needed for the sake of growth.

The path for Scull Creek through the majority of campus is a combination of open-air stormwater and underground stormwater infrastructure. Scull Creek moves across the proposed site from west to east. It exits the underground stormwater infrastructure at Whitham and enters the site by daylighting into what appears to be a natural and undisturbed path. When the surface parking lot in the NE corner of the site was developed an underground storm culvert was used to connect to the creek to the stormwater system running underneath Gregg Avenue. Scull Creek then daylightes just north of the intersection of Gregg Street, Frisco Avenue, and Douglas Avenue. It then travels north for quite sometime running parallel to the Frisco Trail.

The insertion of a large parking facility over a tributary of the Illinois River offers several challenges. An opportunity to strategically daylight the routing of Scull Creek through the parking structure is presented in each option to follow.



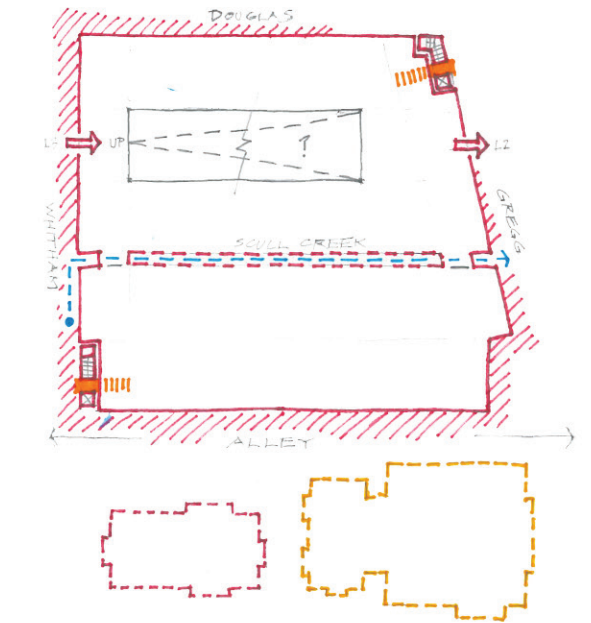
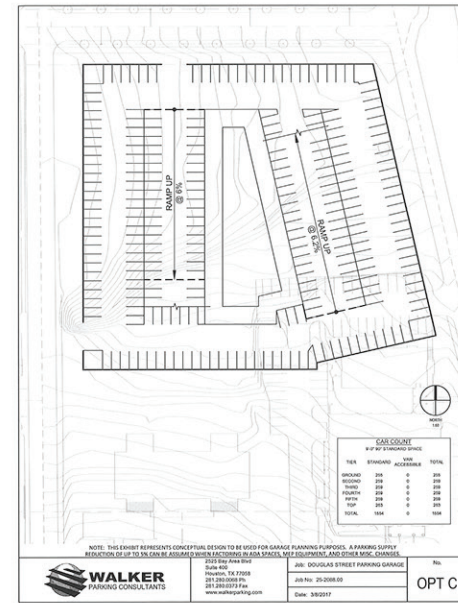
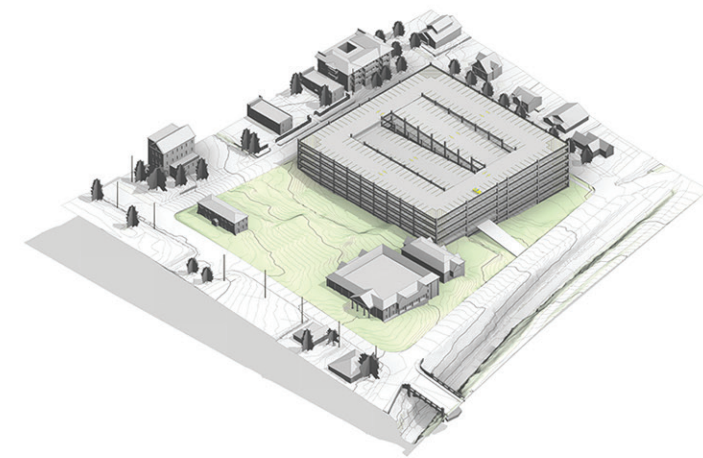
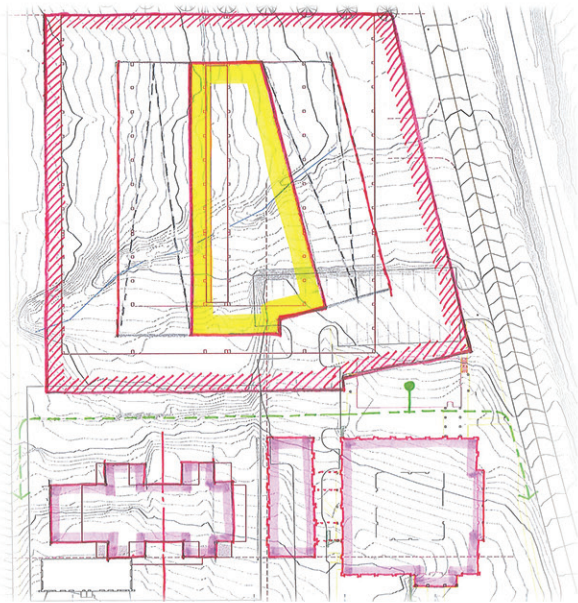
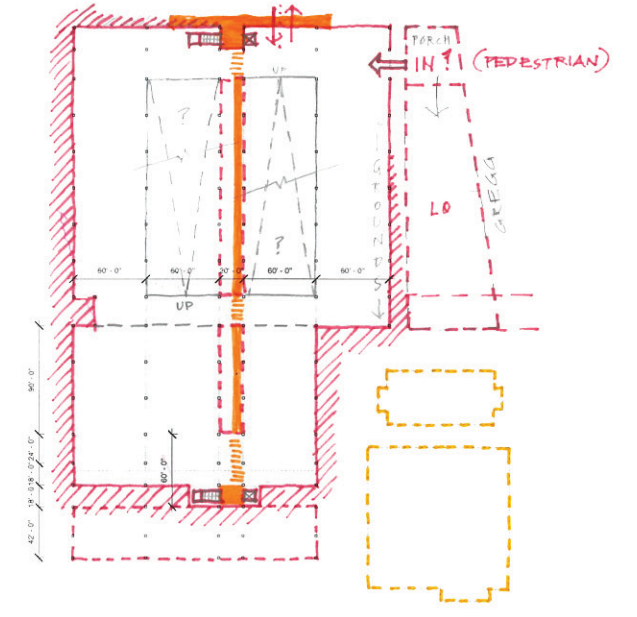
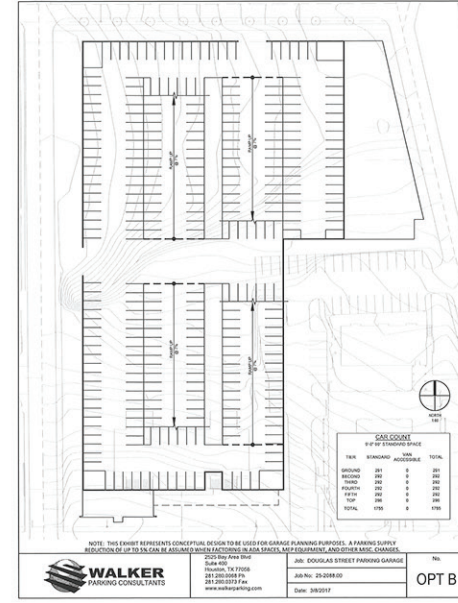
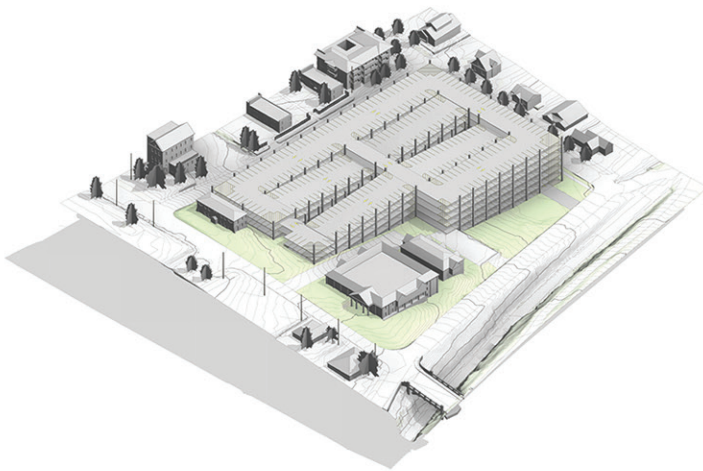
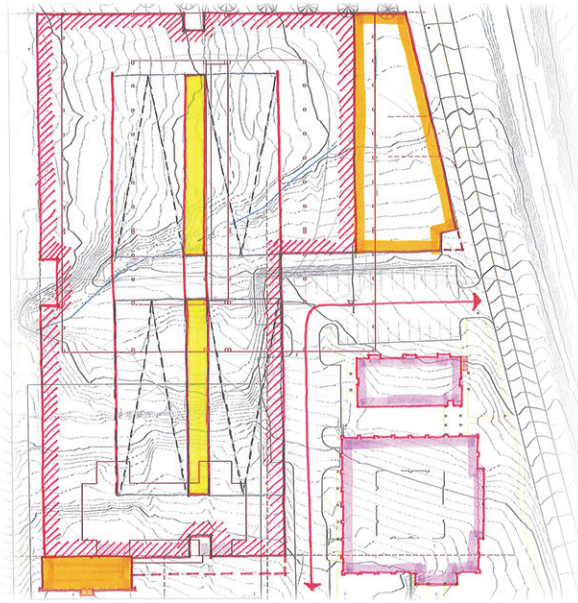
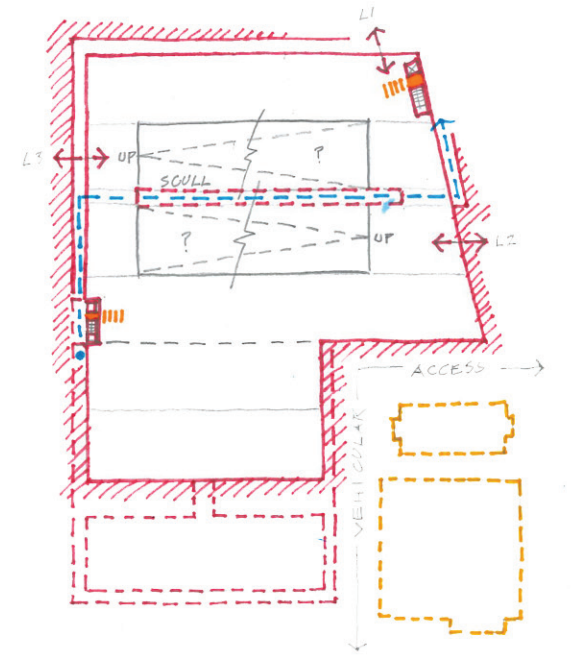
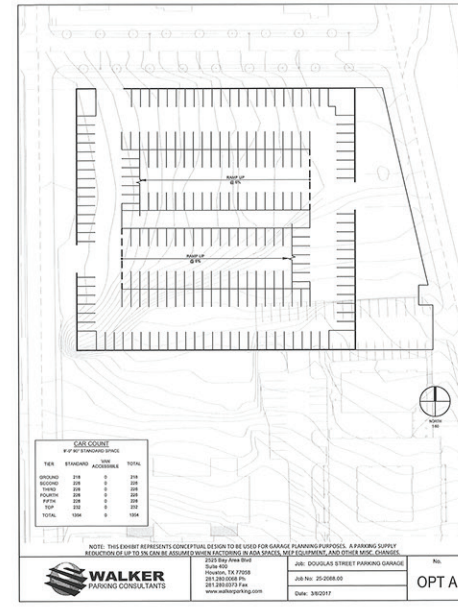
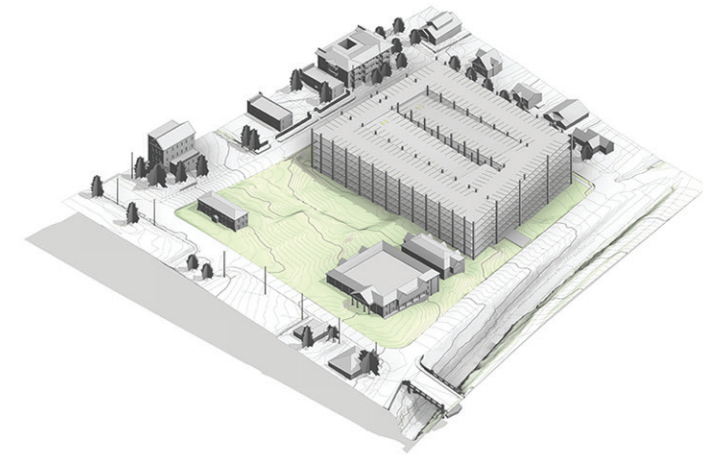
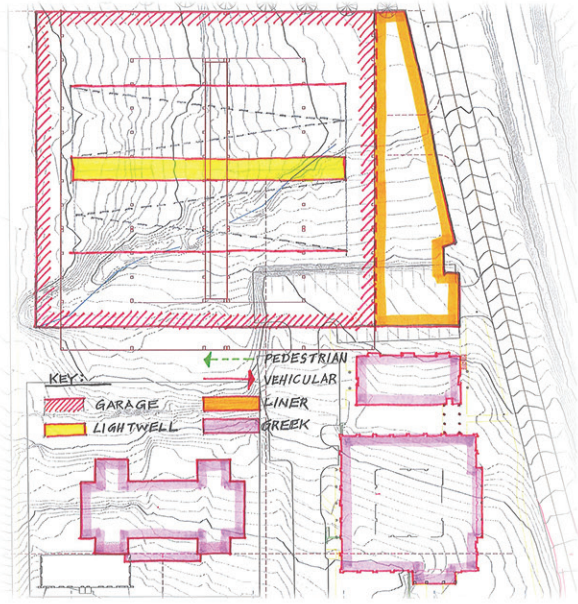

EXPLORATION

Several preliminary options were presented in order to determine how to best utilize the site for structured parking while maximizing the Level of Service (LOS). In the end, three (3) primary layouts were identified as having enough merit and variation to move forward in the study, and they are commonly referred to as Option A (blue), Option B (green), and Option C (orange) throughout the document.

It is important to note that variation between each proposed option was very much deliberate. Several factors were explored and shown for each of the three, but they are not necessarily exclusive to the option they are shown with. For example - the Maple Building is presented in three distinct variations, but all of these configurations are interchangeable with A, B, or C with slight modification.

For consistency, all options under this section are presented as 8 levels tall with 11'-6" floor-to-floor heights. While 8 levels is likely not be the determined outcome it offers a "high end" number for maximum parking spaces possible using each proposed configuration.

Documented in detail at the end of this section is a Matrix of several of the key determinants that were studied to arrive at each proposed option. These include, but are not limited to:

- Overall Parking Count with an initial target of 1,600 to 1,800 spaces - During study it was determined that final parking count is a result of several factors and not necessarily a targeted goal
- Vehicular Access Points exploring both quantity, location, and level served
- Typical Structural Bay which can determine straight or angled parking and direction/flow of traffic
- Management of Scull Creek as it passes through proposed site providing a clear path separated from typical storm water
- Solution for inclusion of Sigma Chi Fraternity at SE corner of proposed site studying shared pedestrian and vehicular access
- Treatment of "Maple Building" providing frontage for the portion of our site that presents itself to campus

It is not the intent of this study to show preference, but rather show as many viable options as possible to help inform the decision making process.

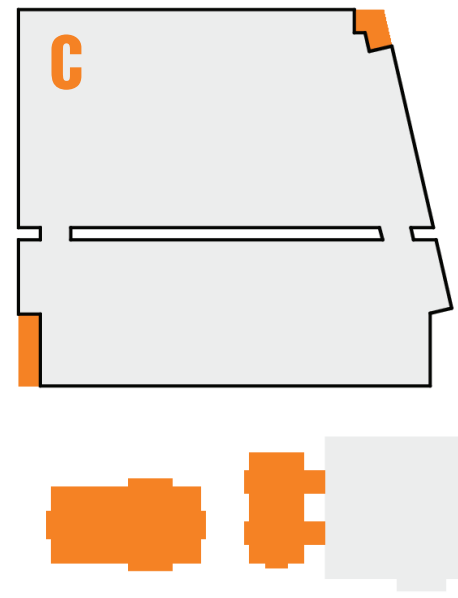
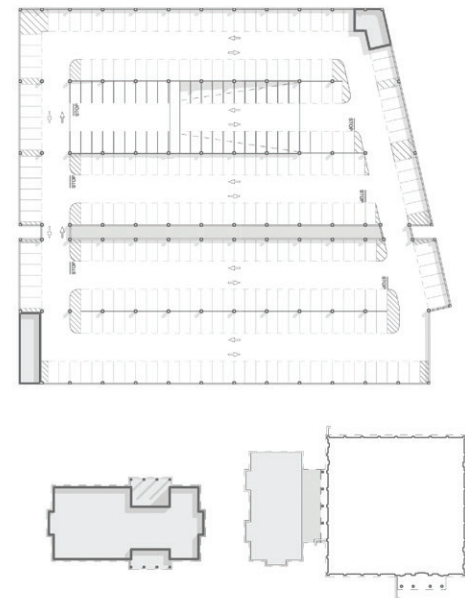
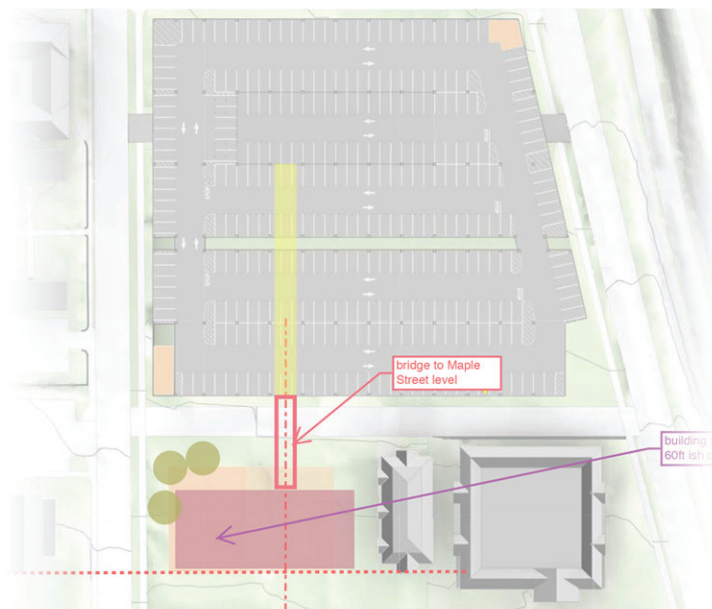
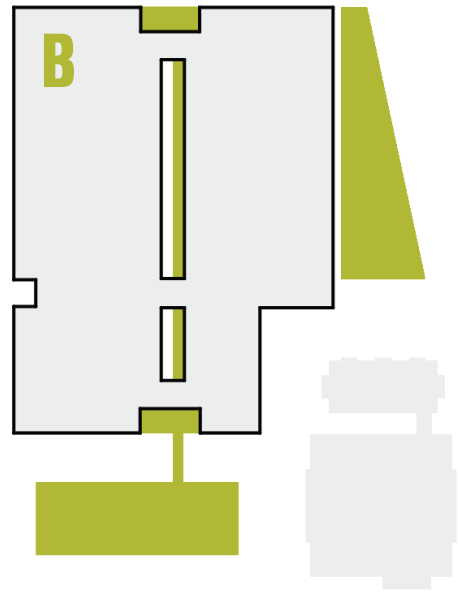
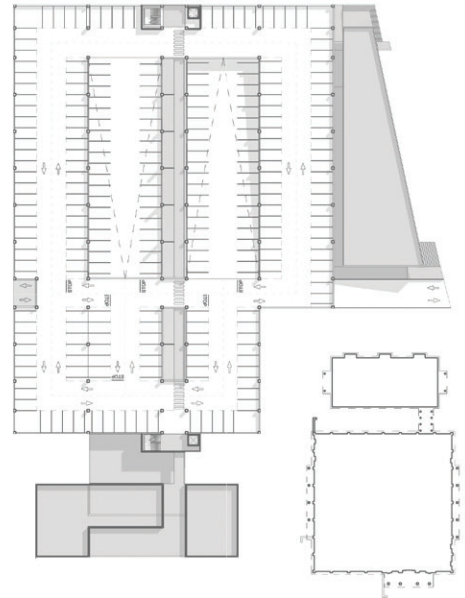
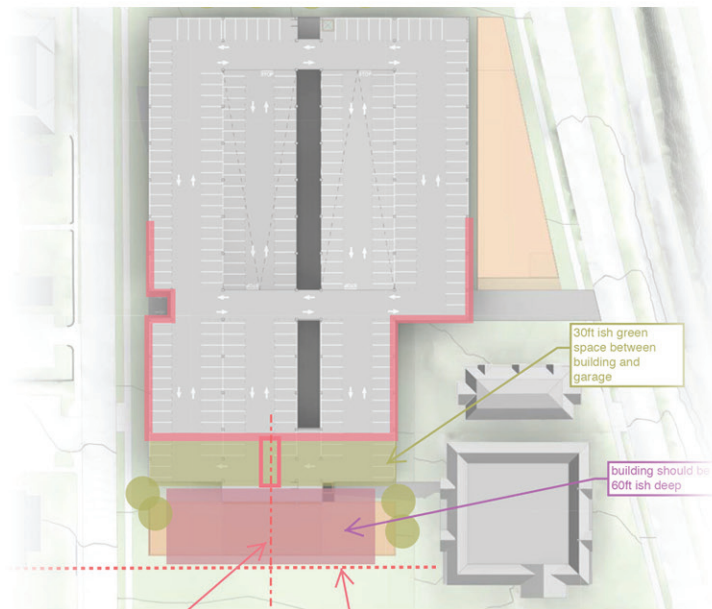
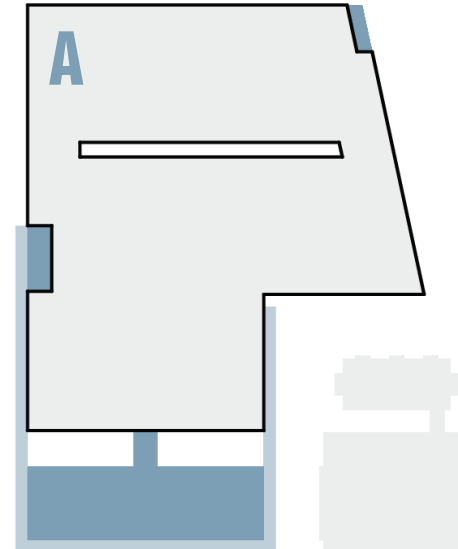
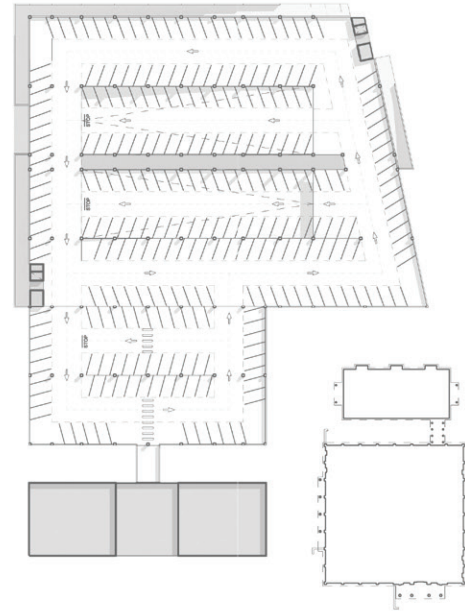
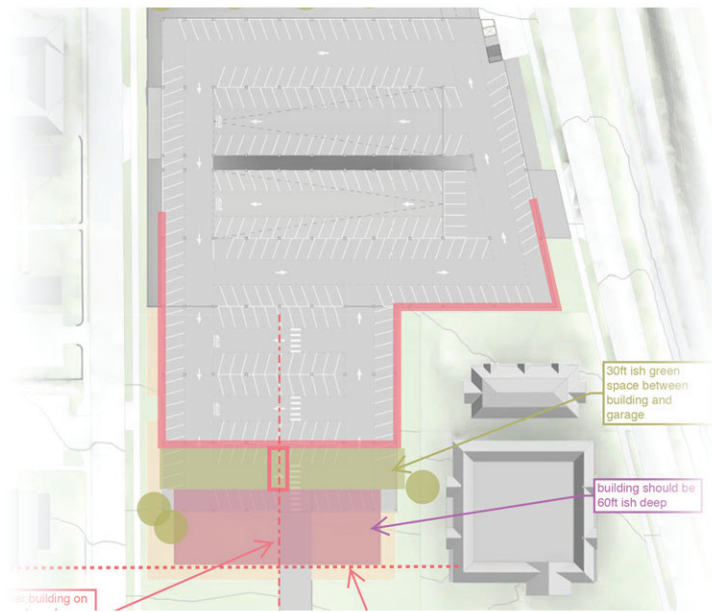

● ACCESS FROM DOUGLAS

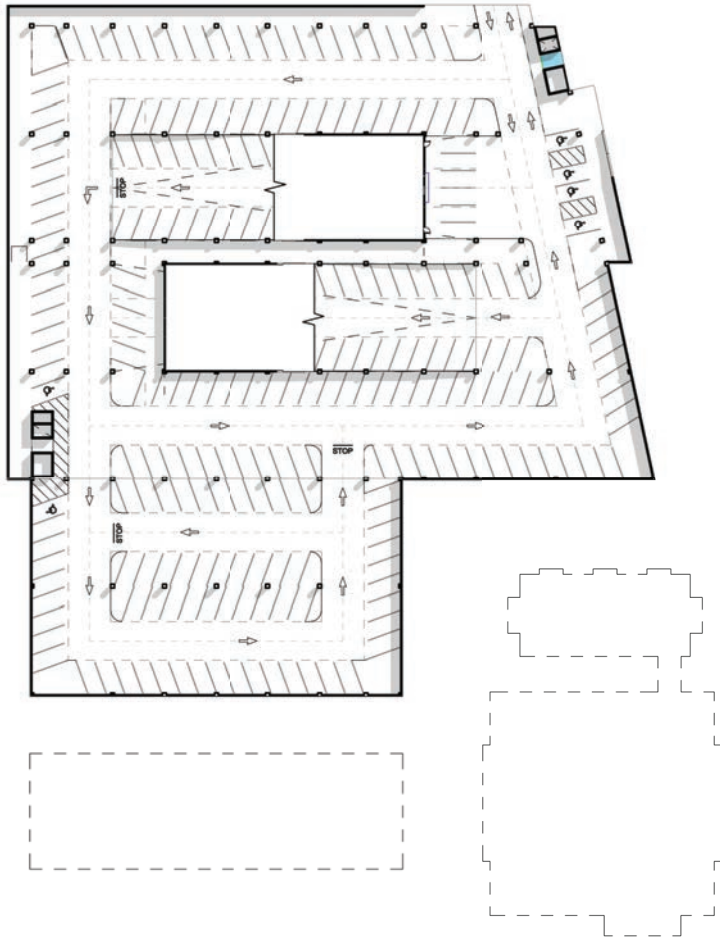

LEVEL 1 - 195 SPACES

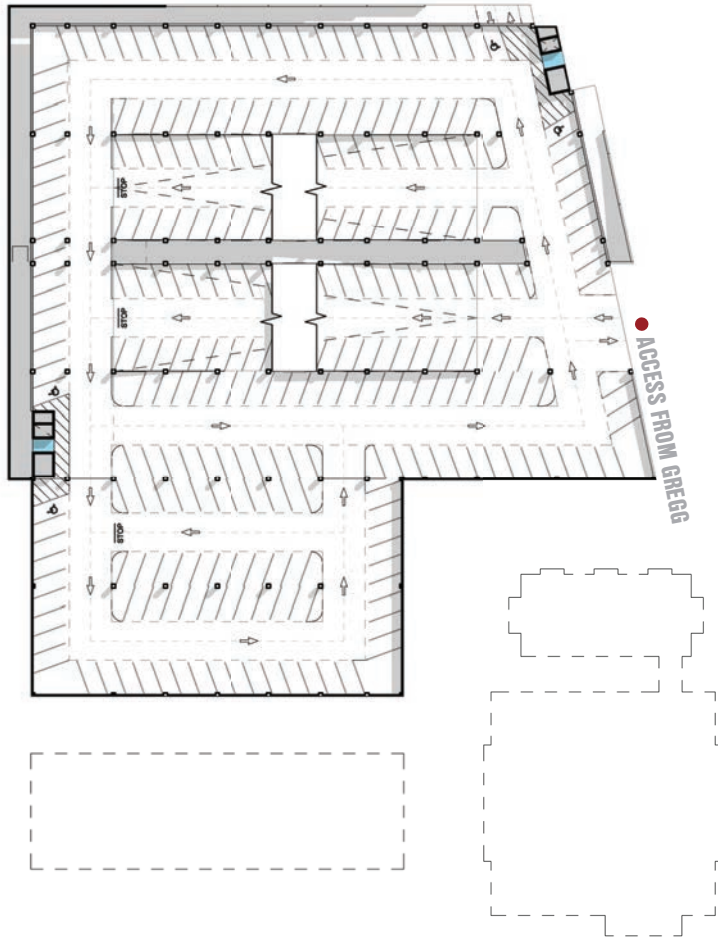

LEVEL 2 - 264 SPACES

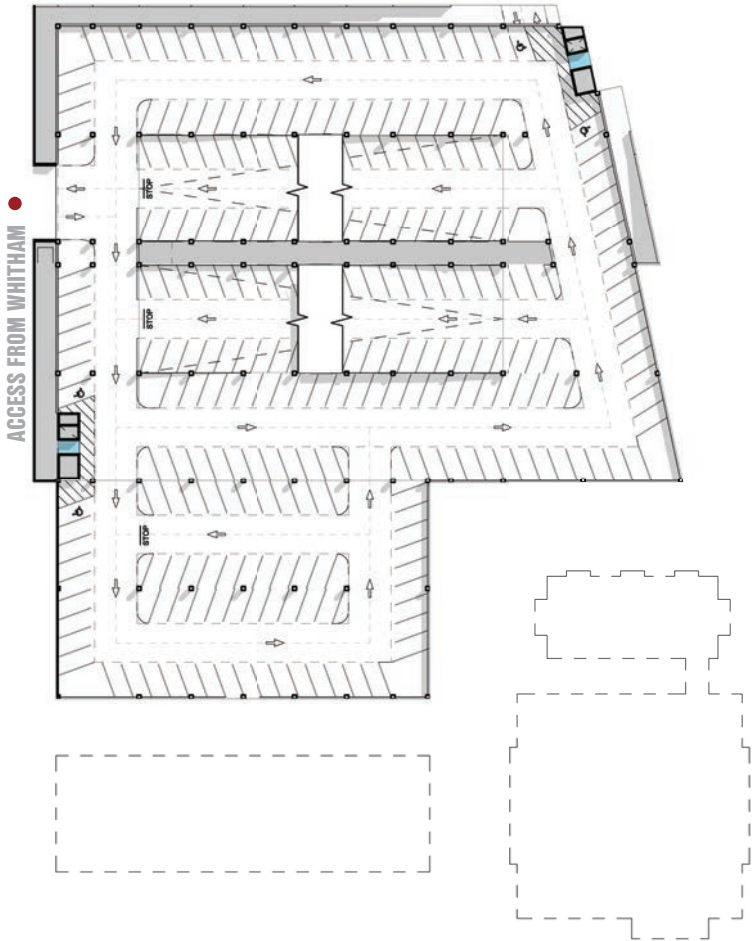

LEVEL 3 - 263 SPACES

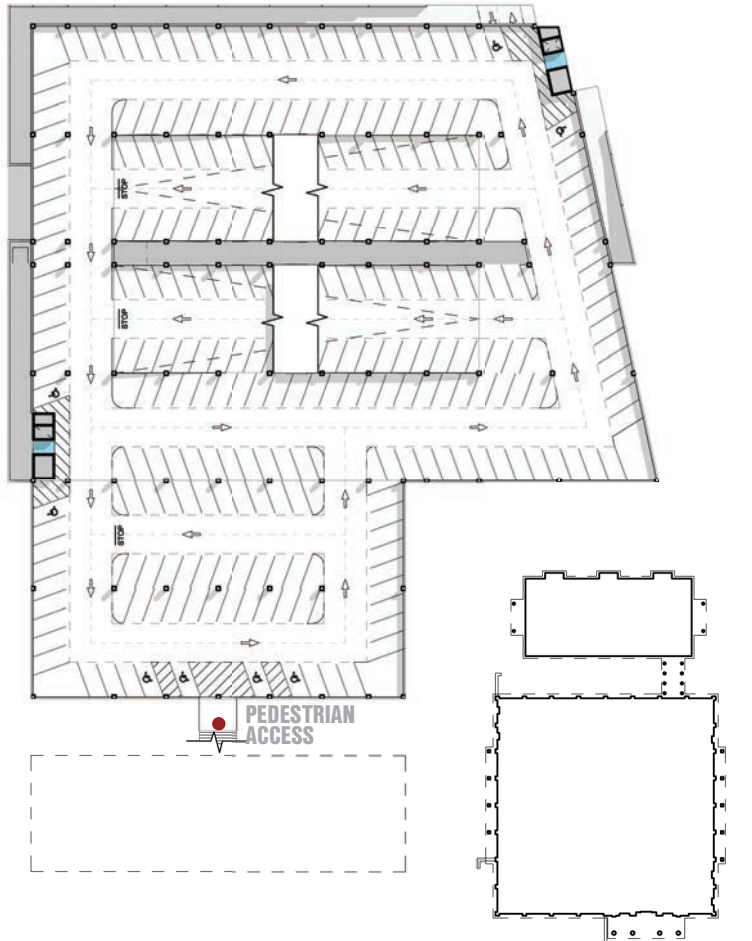

LEVEL 4 - 265 SPACES

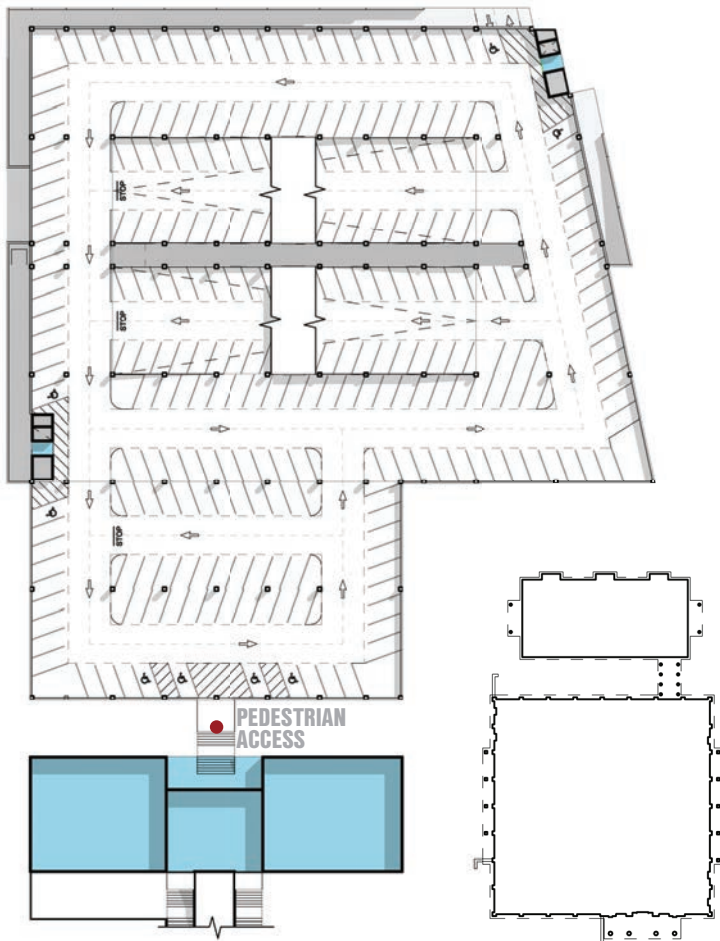

LEVEL 5 - 265 SPACES

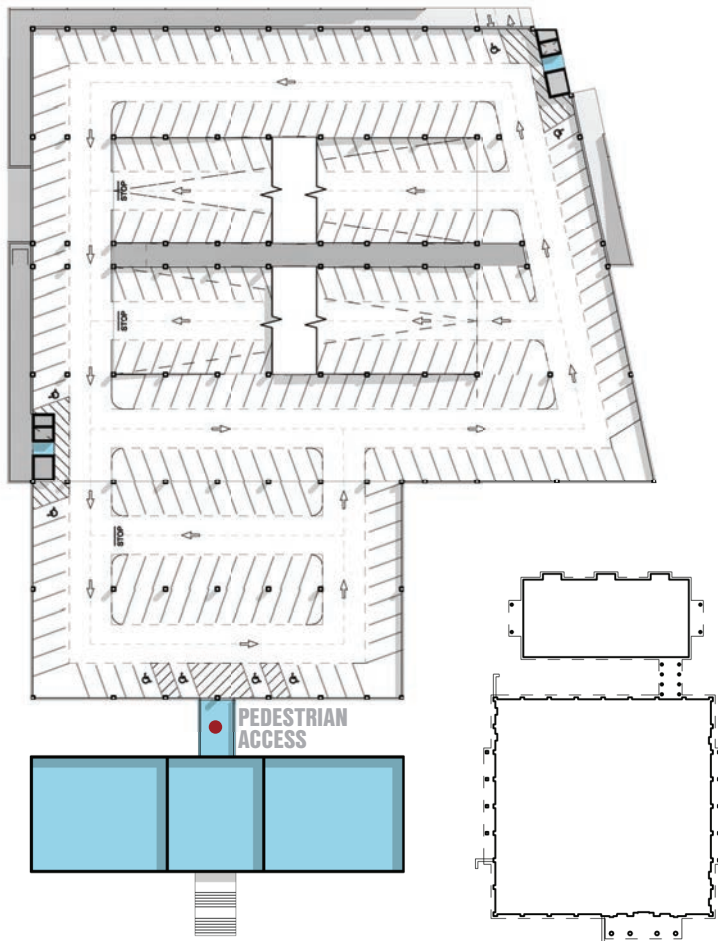

LEVEL 6 - 265 SPACES

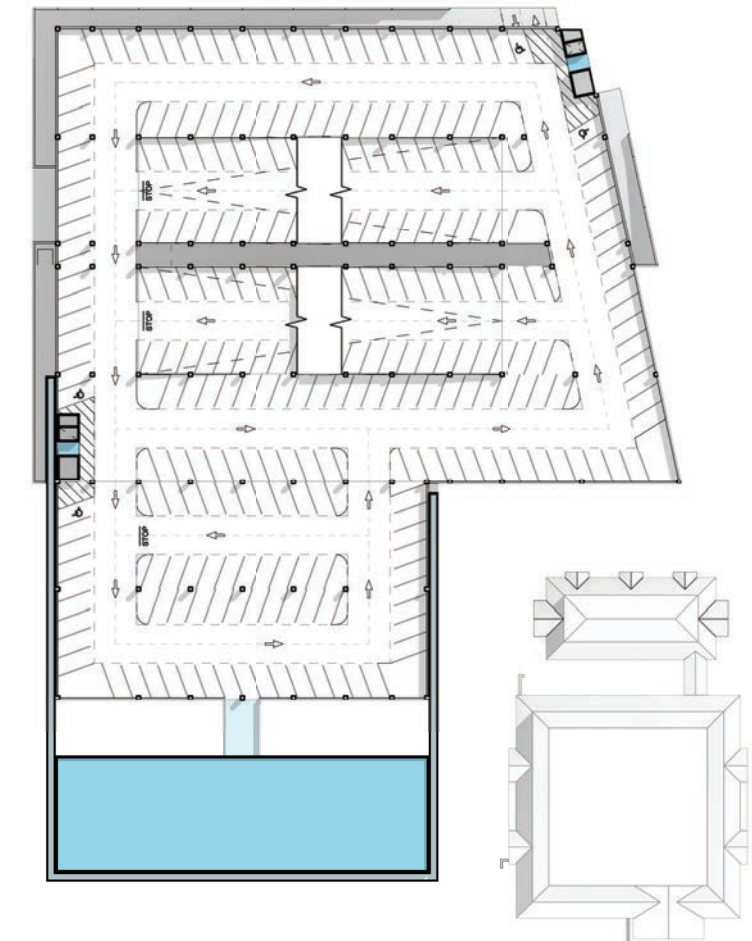

LEVEL 7 - 270 SPACES

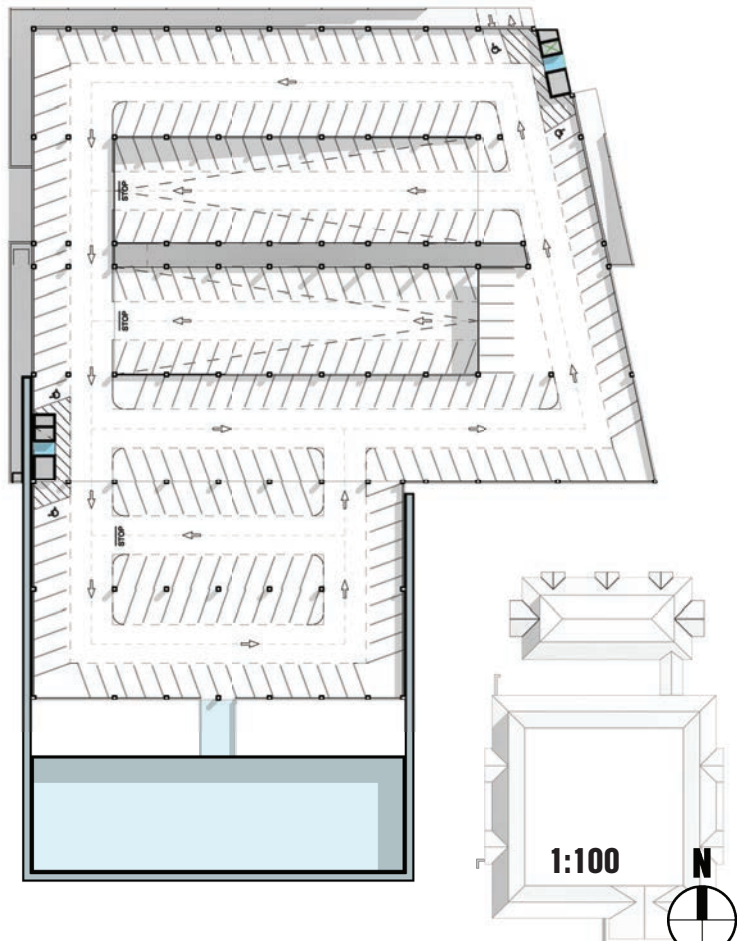

LEVEL 8 - 270 SPACES

1:100 N

OPTION A

Option A proposes a parking garage with six (6) parking bays running in the east/west direction. The 4 northernmost primary bays are split by a lightwell that is open from top to bottom. Parking ramps running in opposite directions flank either side of the lightwell. Further excavation and retaining create a perimeter lightwell at the lower levels around Whitham and Douglas. This feature provides additional daylight, but more importantly leaves a higher percentage of the garage's perimeter open for natural ventilation. The two southern bays are shortened in length due to proximity of the Sigma Chi House and Annex, but maintain a traffic loop through both tying it back to the main deck. A small Level 1 area of parking adjacent to and under the parking ramp has been identified as a potential landing spot for the campus Grounds Crew (see plan).

By limiting the traffic to one-way and providing angled parking, the typical structural bay is reduced to a width of 56'-0" consisting of a 20'-0" clear width one-way drive lane. This reduction allows for 6 bays in the north/south direction while still maintaining adequate space to the south for a future building on Maple.

The garage is striped with 9'-0" wide parking spaces and this results in a range of 1,396 to 2,057 depending on number of parking levels – see Matrix for further detail.

The garage utilizes three individual vehicular access points distributed as follows:

- Level 1 - Douglas Street (Grounds Crew)
- Level 2 - Gregg Avenue
- Level 3 - Whitham Avenue

Scull Creek enters the perimeter lightwell near the existing storm outlet on Whitham and travels due north until turning east under the primary vehicular drive. Once it reaches the lightwell it moves across the deck, open to ventilation, yet separated from deck run-off. The creek is then routed into existing stormwater infrastructure underneath Gregg before eventually daylighting northeast of the project limits.

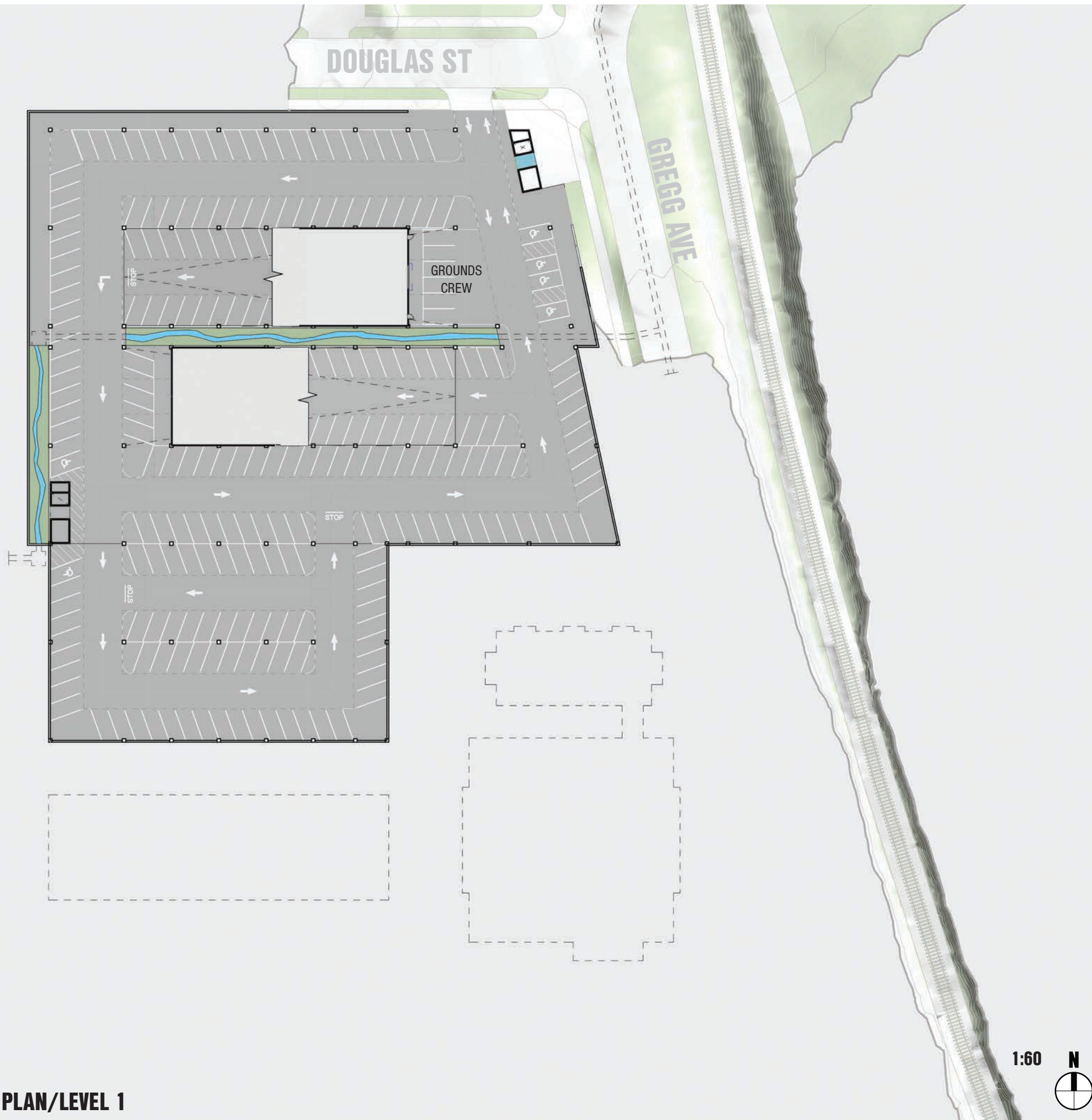

A typical ramp with a length of 189' and a floor to floor height of 11' - 6" results in a slope of 6.0%.

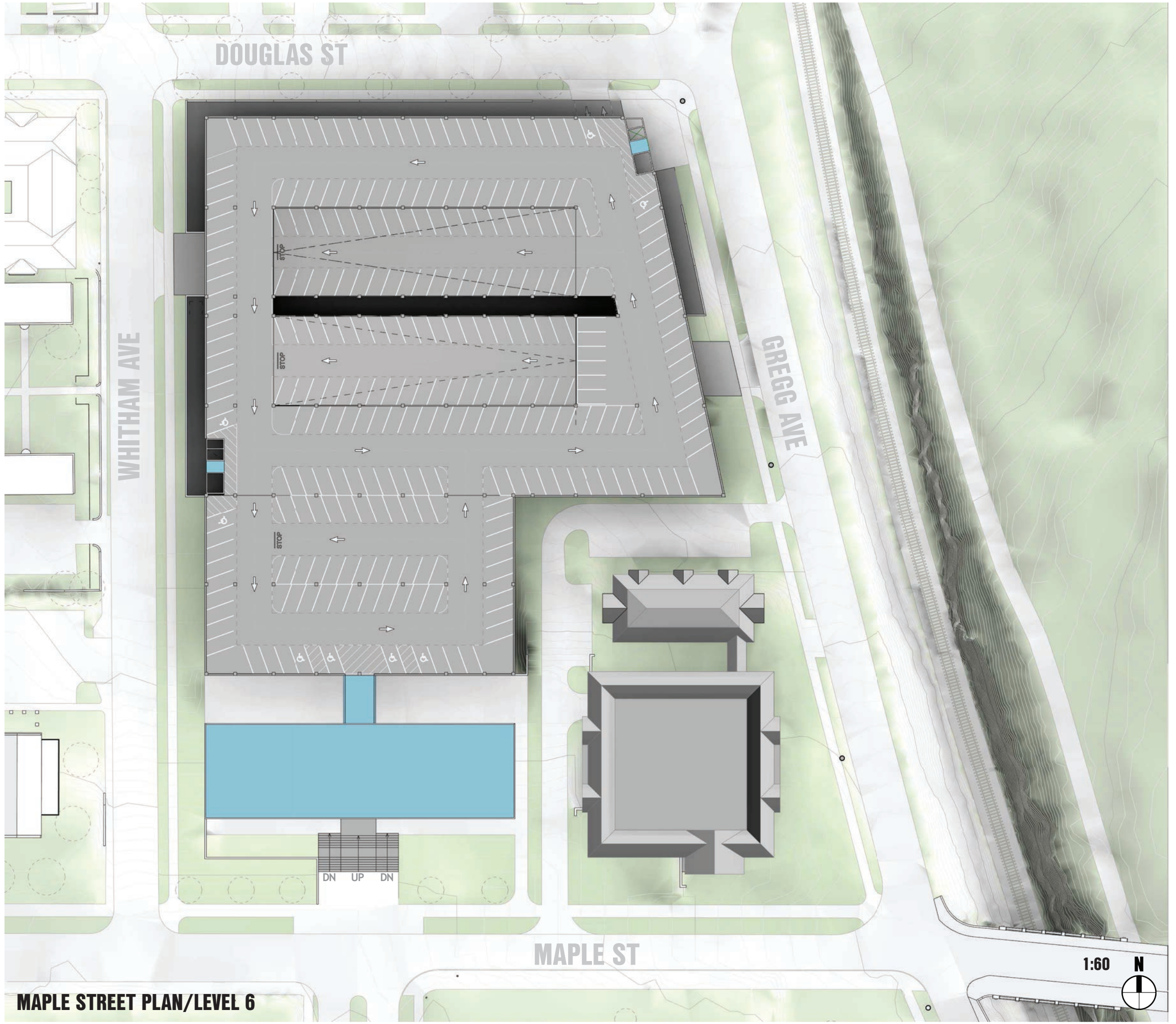
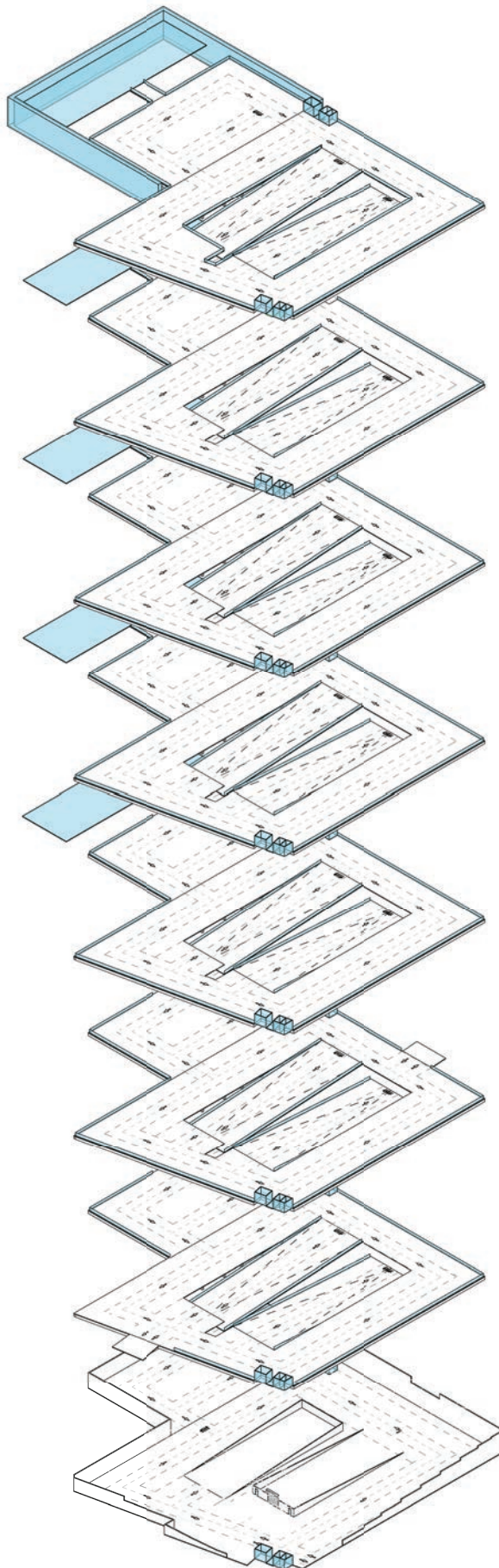

MAPLE STREET PLAN/LEVEL 6

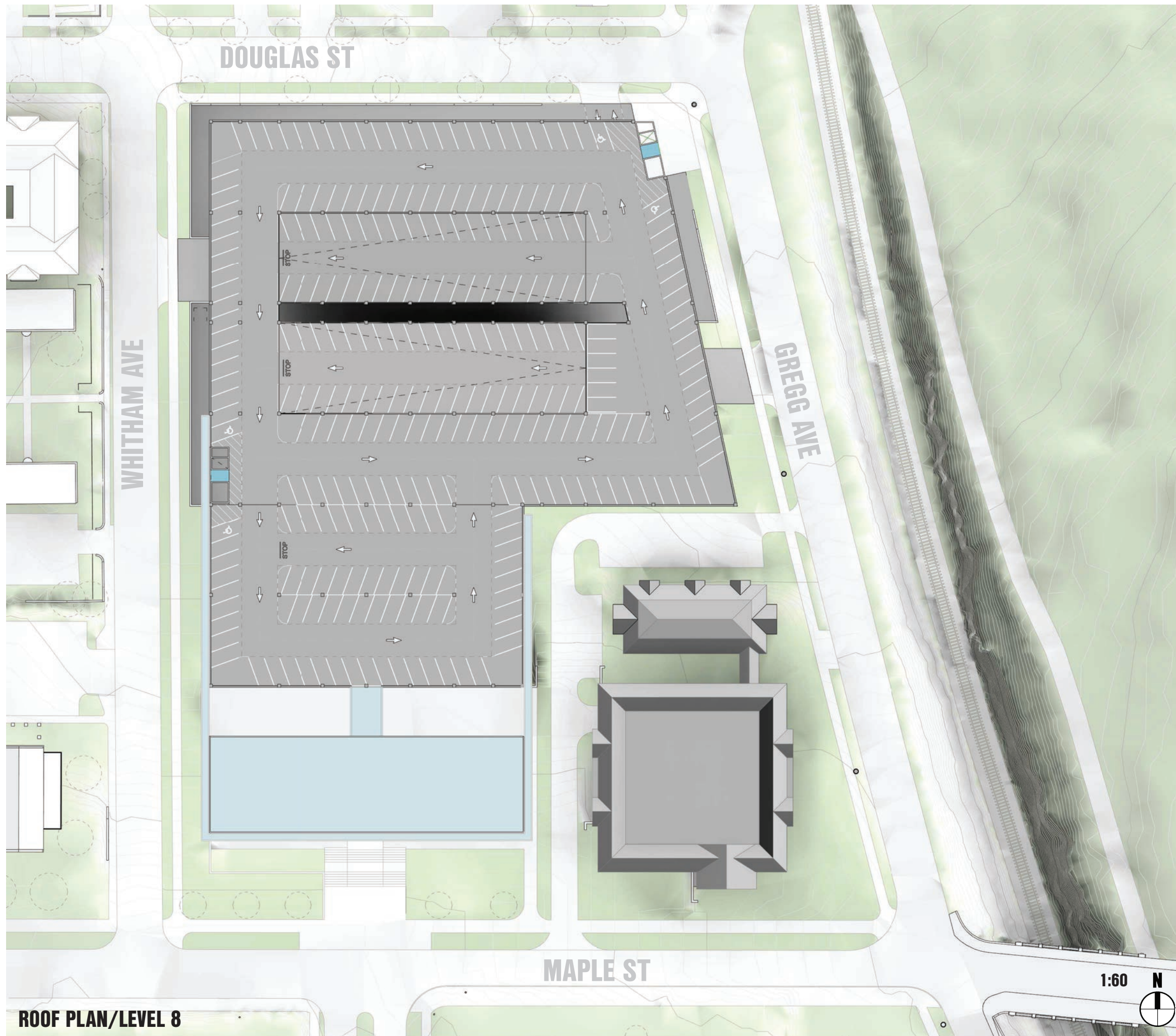

OPTION A (CONT.)

Sigma Chi Fraternity remains more or less untouched under this scenario. While some perimeter parking is removed, a vehicular loop remains allowing access to both Gregg and Maple. This does leave limited on-site parking for Sigma Chi and maintains service/maintenance access close to what they are accustomed to.

A proposed building fronting Maple is shown in a configuration that might be classified as a “liner” building. The footprint maintains the same structural width the southern bays of the garage and an implied “wrapper” material might act as a screen that ties the two structures together. The building’s primary floor is raised slightly above street level allowing clear access through and directly into Level 6 of the garage. The lower level is carved into the site and opens to north, stepping down to communicate with Level 4 of the garage.

Providing a maximized parking configuration based on space available and better than average LOS, Option A is a good fit if minimal disruption to Sigma Chi is preferred.

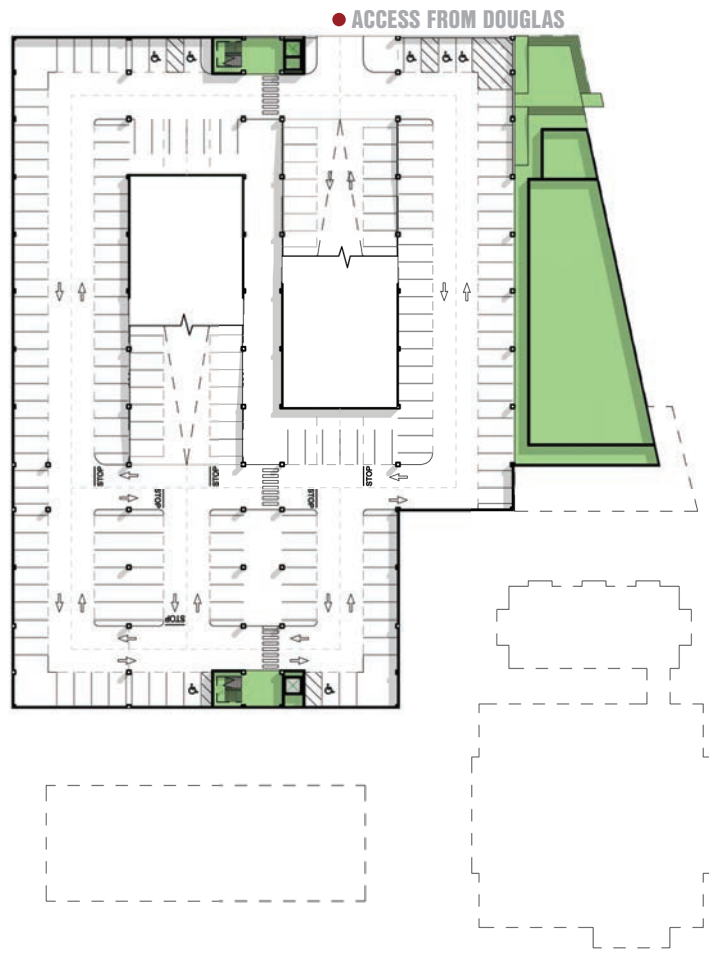

LEVEL 1 - 160 SPACES

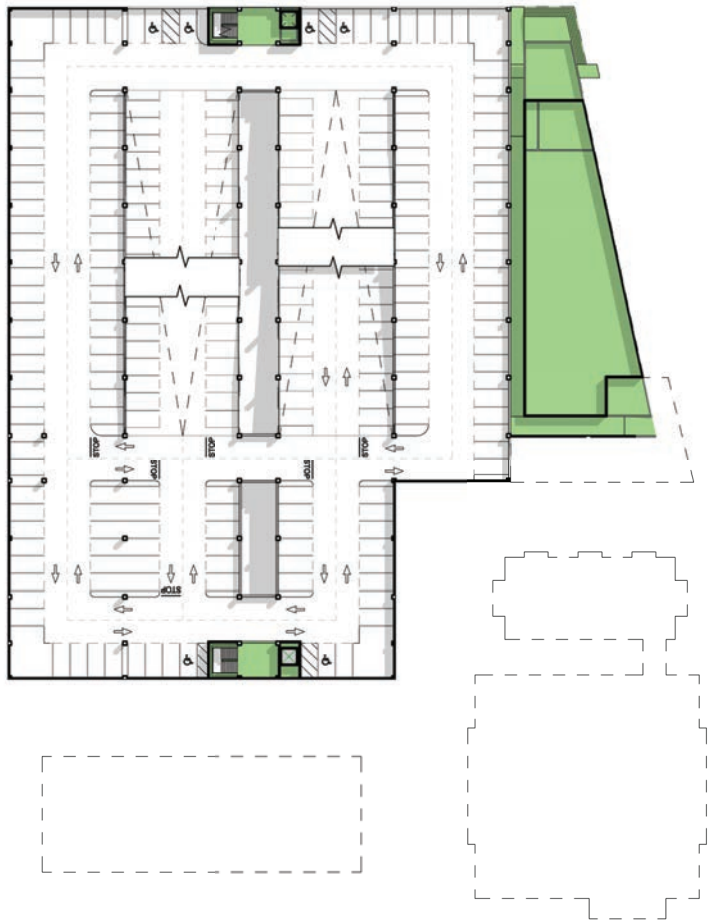

LEVEL 2 - 229 SPACES



LEVEL 3 - 223 SPACES

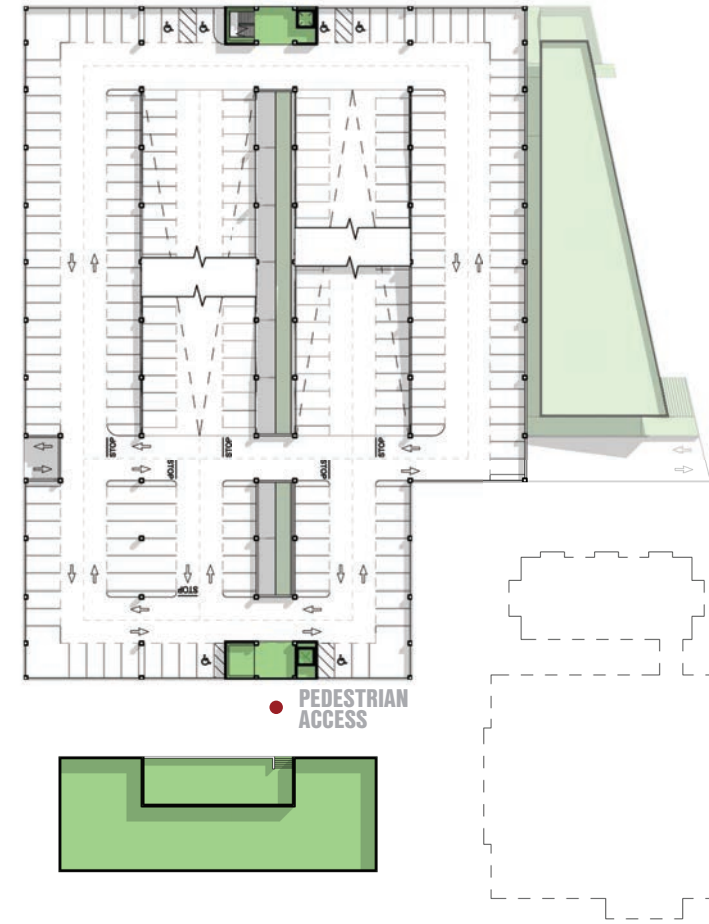

LEVEL 4 - 226 SPACES

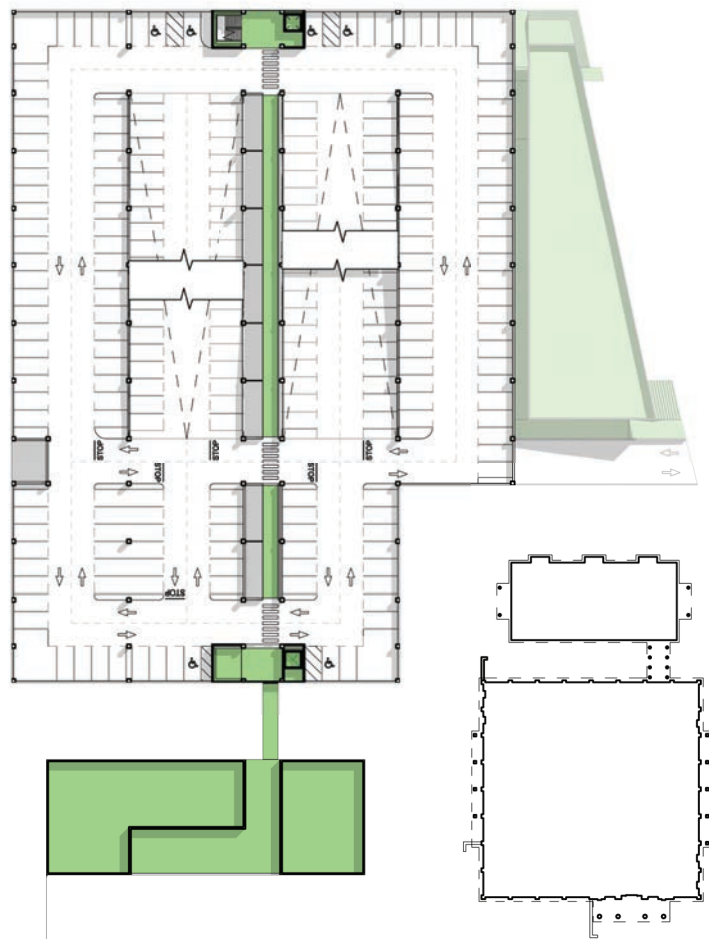

LEVEL 5 - 226 SPACES

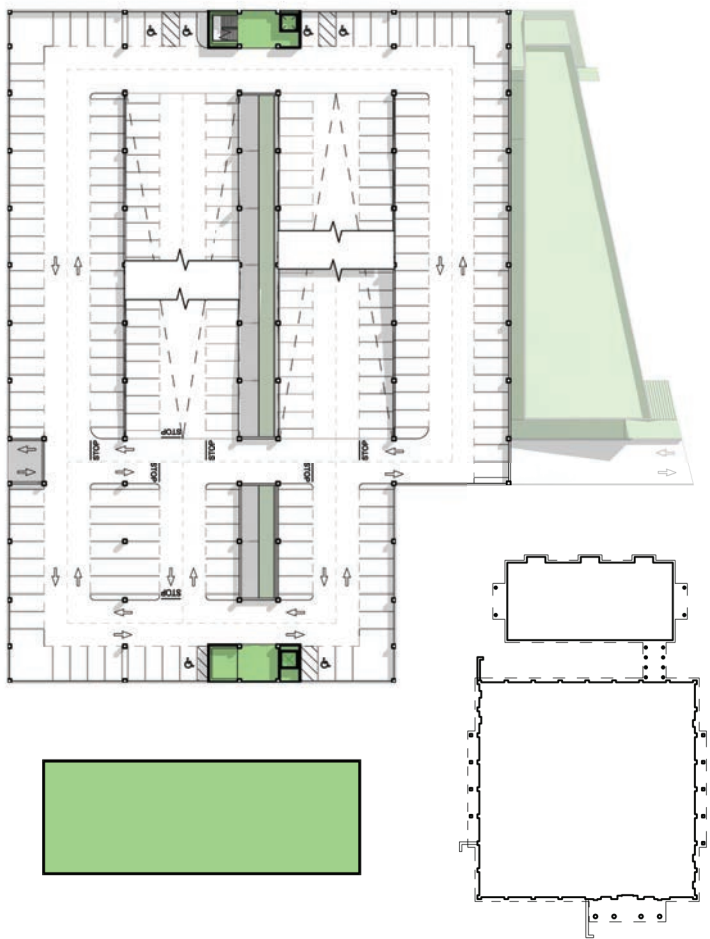

LEVEL 6 - 226 SPACES

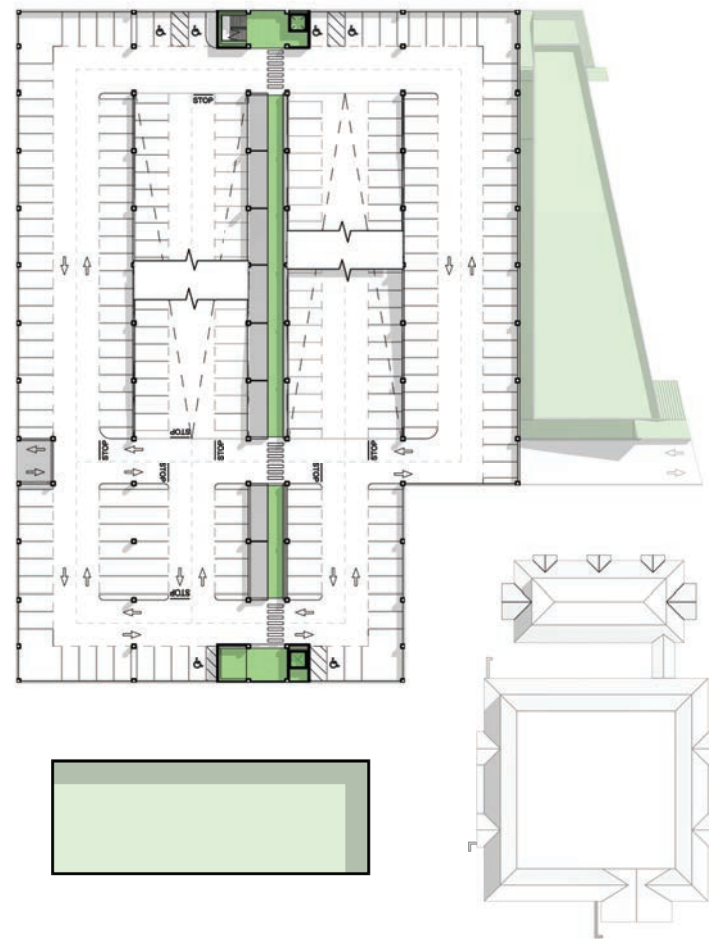

LEVEL 7 - 226 SPACES

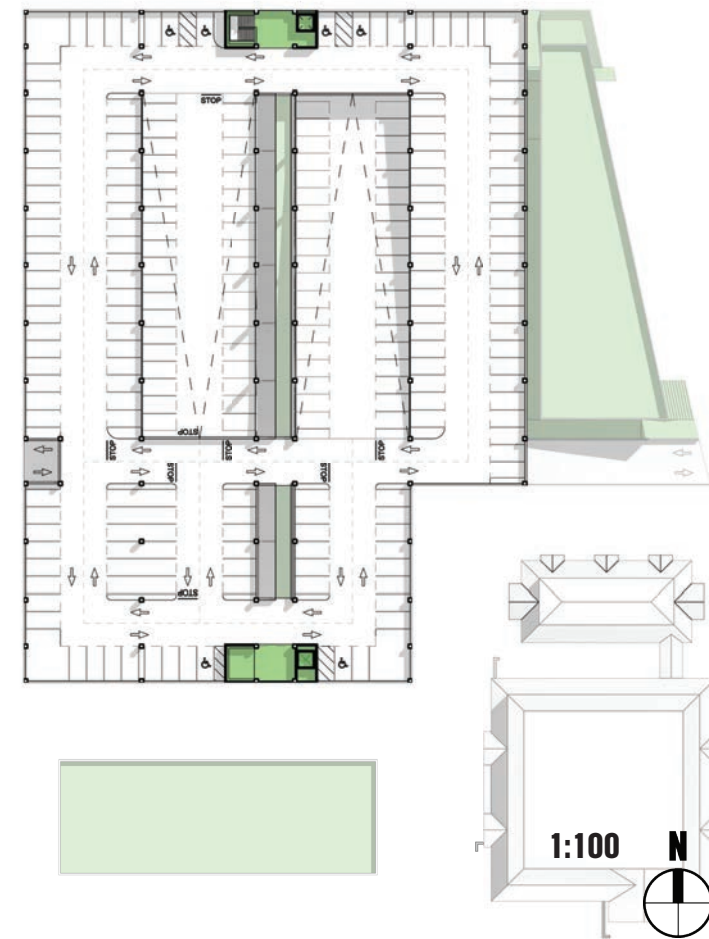

LEVEL 8 - 226 SPACES

OPTION B

Option B proposes a parking garage with four (4) parking bays running in the north/south direction. The primary bays are divided down the middle by a lightwell that is open from top to bottom. Parking ramps running in opposite directions flank either side of the lightwell. The vertical circulation is organized on either end of the north/south lightwell and a clearly marked and protected pedestrian path runs along this axis. The pedestrian path is continued above by means of a bridge on levels 3, 5, and 7. The eastern most bay is shortened in length due to proximity of the Sigma Chi House and Annex, yet is still included in the primary vehicular loop within the deck.

The parking is arranged within typical structural bays of 60'-0" x 30'-0". This allows for a standard two-way drive width of 24'-0" and results in slightly more than 3 spots per bay.

The garage is striped with 9'-0" wide parking spaces and this results in a range of 1,186 to 1,742 depending on number of parking levels - see Matrix for further detail.

The garage utilizes a Level 3 vehicular "thoroughfare" that bisects the garage just south of both parking ramps providing instant access to levels 2 (ramp down), 3 (exterior bays), and 4 (ramp up). This results in an organized entry/exit sequence resulting in three individual vehicular access points:

- Level 1 - Douglas Street
- Level 3 - Gregg Avenue (thoroughfare through to Whitham)
- Level 3 - Whitham Avenue (thoroughfare through to Gregg)

Scull Creek would be diverted under Level 1 to the east from the existing storm outlet on Whitham until it reaches the north/south lightwell. Once it reaches the lightwell it travels north (parallel to the primary pedestrian path), open to ventilation, yet separated from deck run-off. The creek is then routed into existing stormwater infrastructure underneath Douglas before eventually daylighting northeast of the project limits.

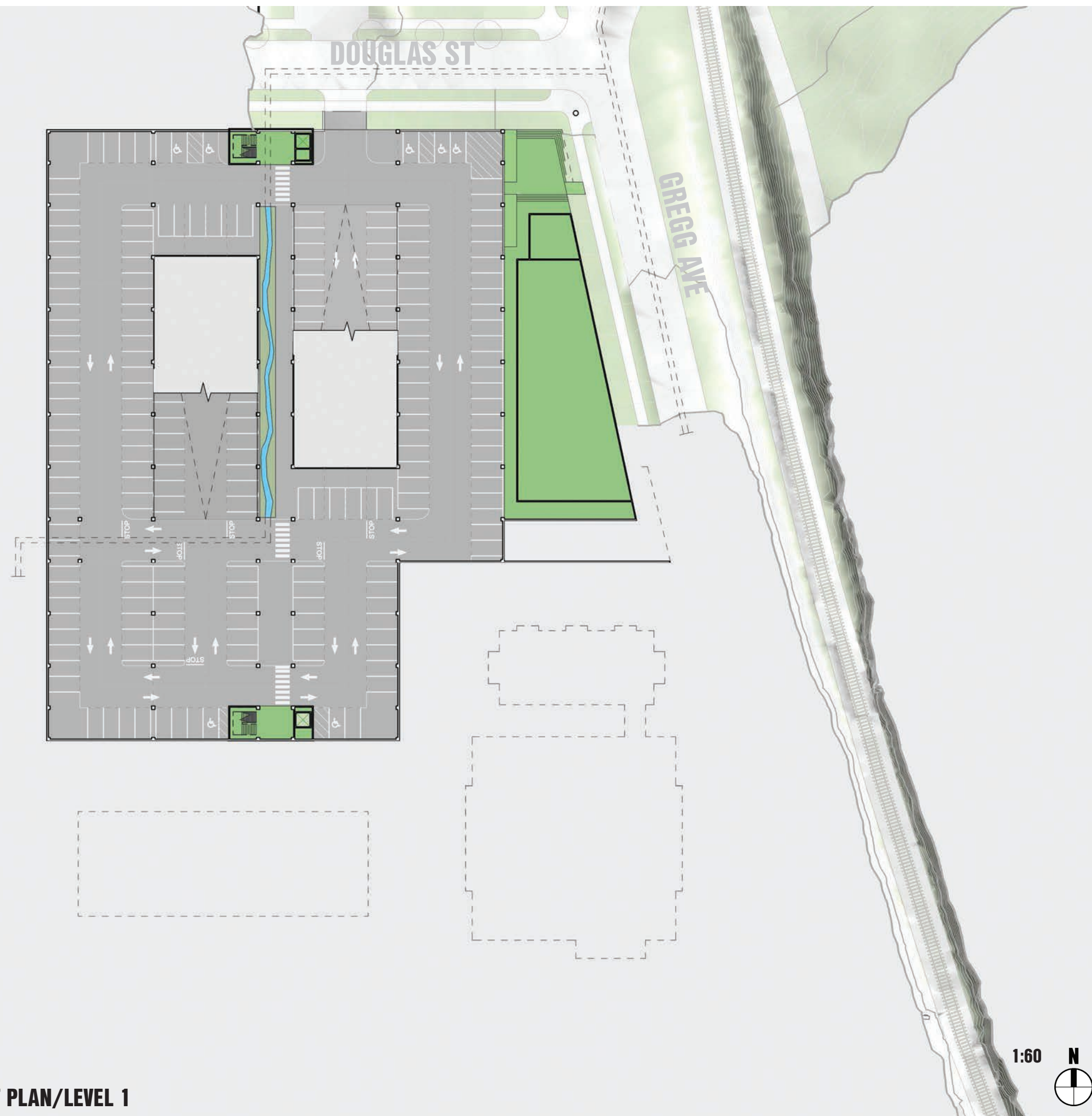

A typical ramp with a length of 180' and a floor to floor height of 11' - 6" results in a slope of 6.4%.

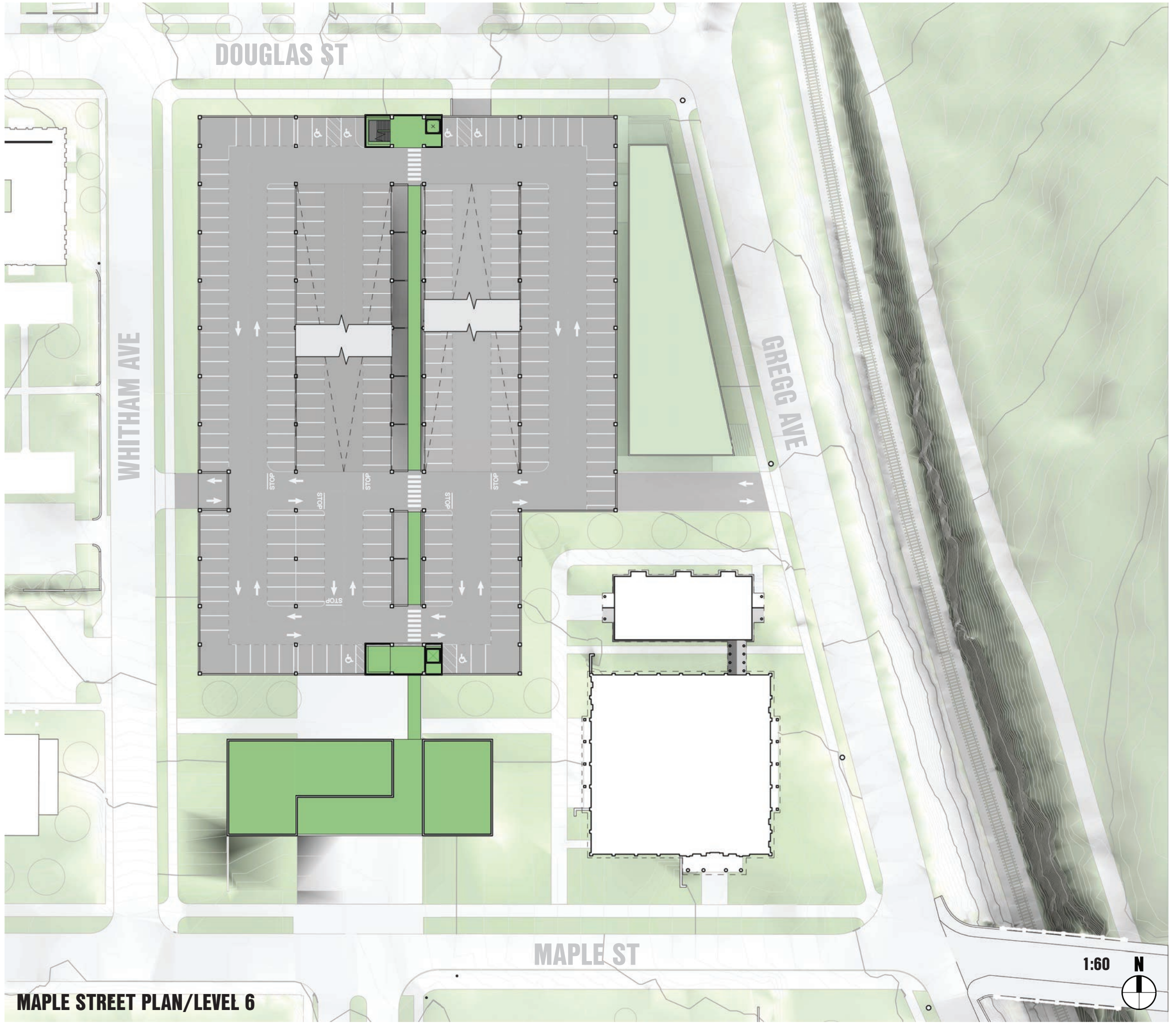
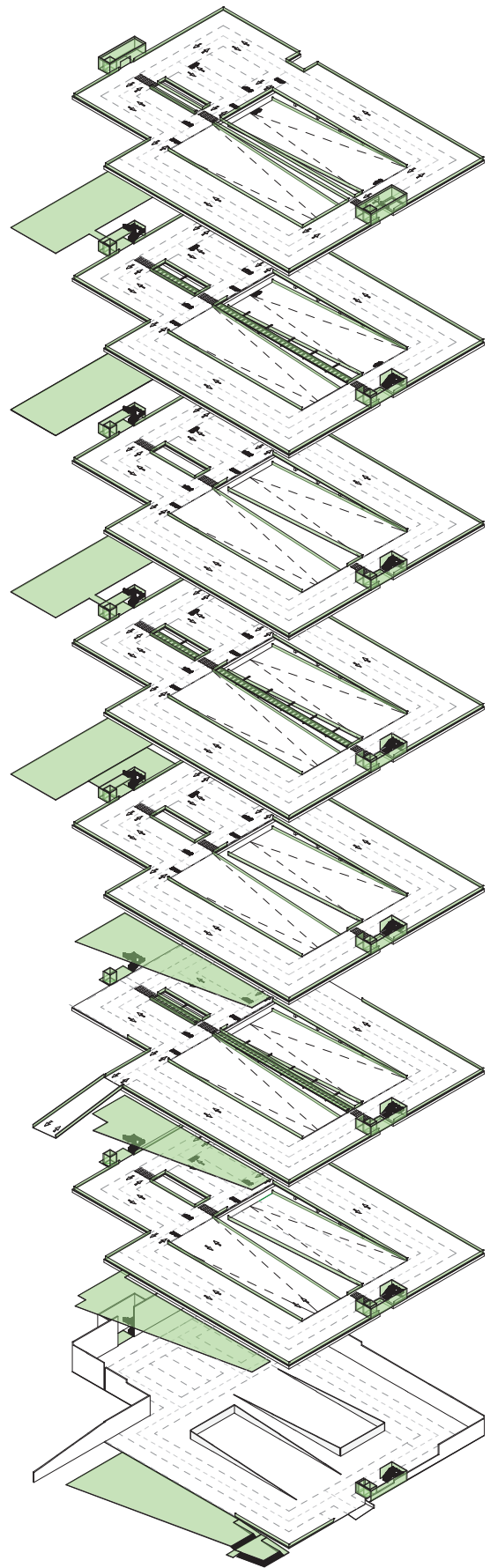

MAPLE STREET PLAN/LEVEL 6

1:60 N

OPTION B (CONT.)

While the Sigma Chi structures remain untouched in this proposed option, vehicular access (including all surface parking) is removed from the property. A new green space with protected pedestrian access to and from the garage is proposed. This green “buffer” creates an acceptable separation between two distinct uses - Parking and Greek Housing. Since their current parking is eliminated, it is proposed that a certain number of preferred spaces on Levels 3 and 4 are allocated for Sigma Chi.

A proposed building fronting Maple is shown as a stand-alone structure with a bridged connection to Level 5 of the garage and an open grade connection between Level 4 and a lower level of the Maple Building. A second structure is shown along the Gregg Avenue façade and should be considered a liner building that masks the first three levels of the garage. A proposed “porch” marks the corner of Douglas and Gregg and creates an entry from the Frisco Trail.

Option B strikes a favorable balance of maintaining as much of Sigma Chi as possible while maximizing two-way parking that results in a high LOS.

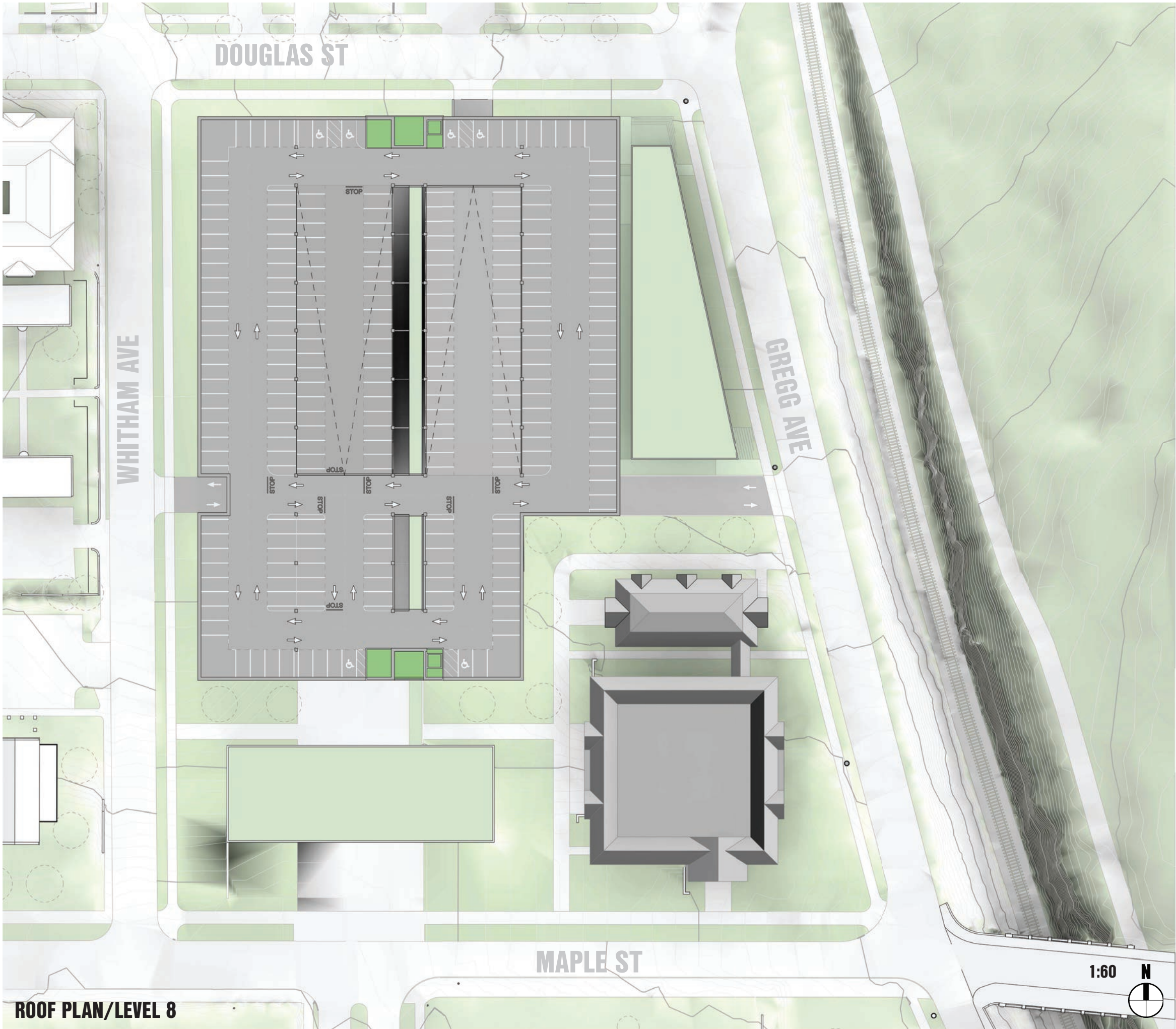

ROOF PLAN/LEVEL 8

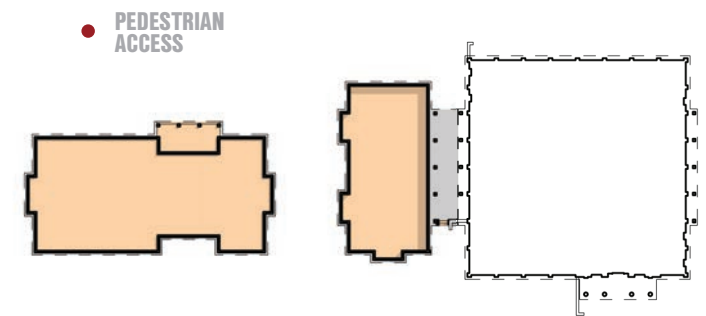
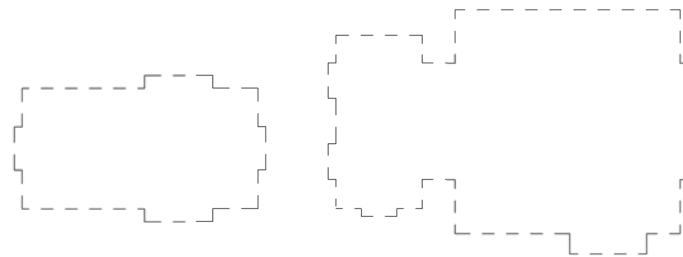
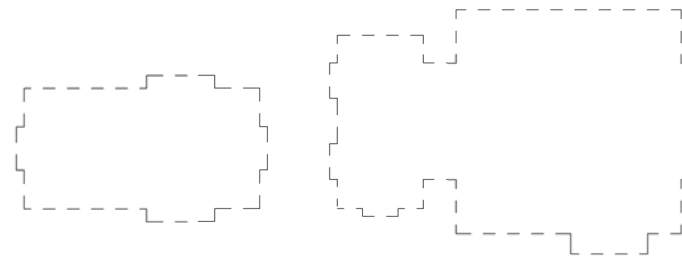
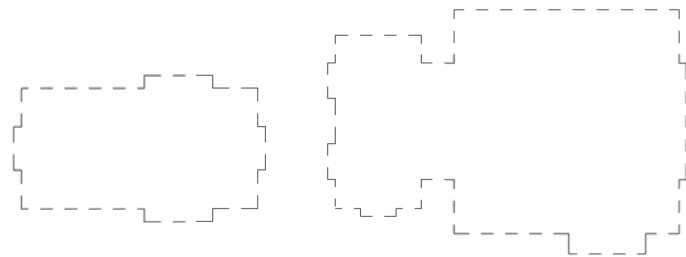
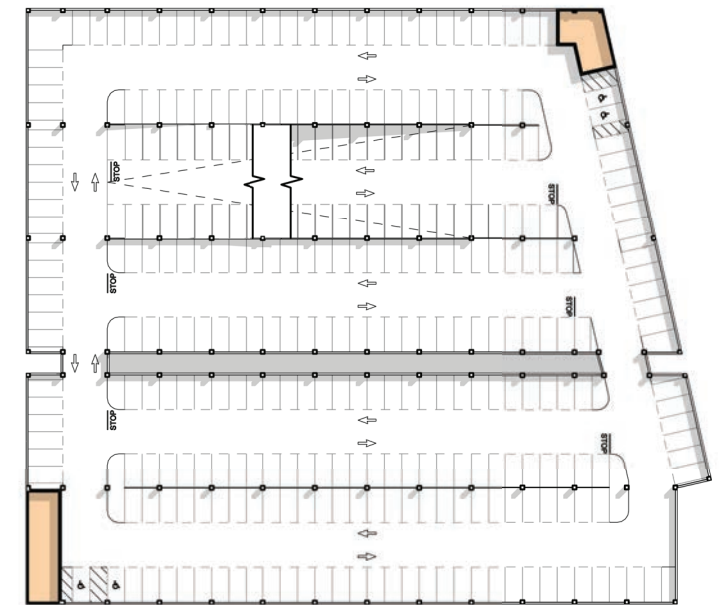
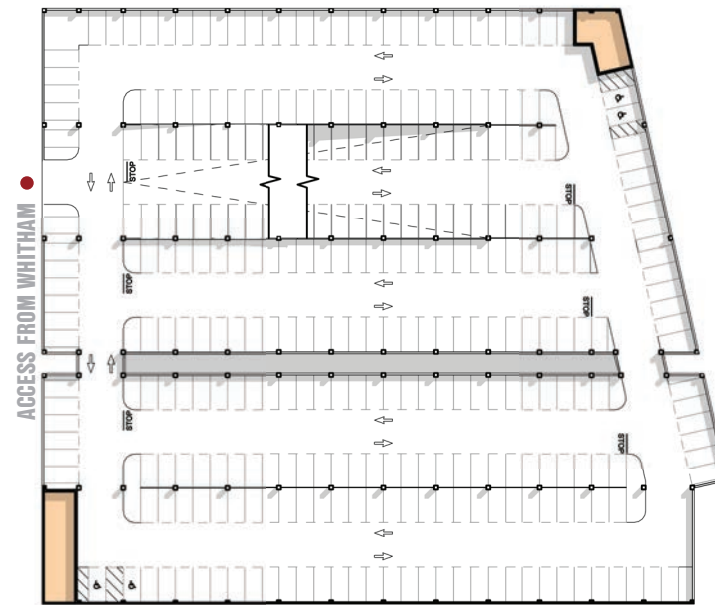
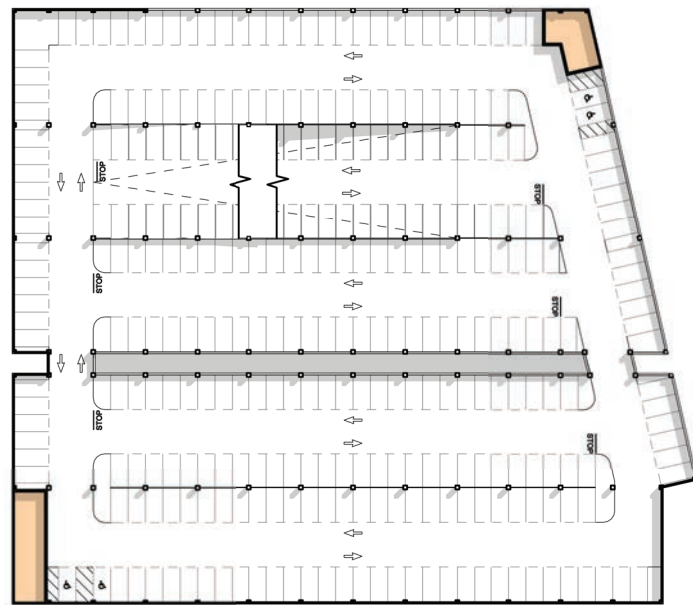
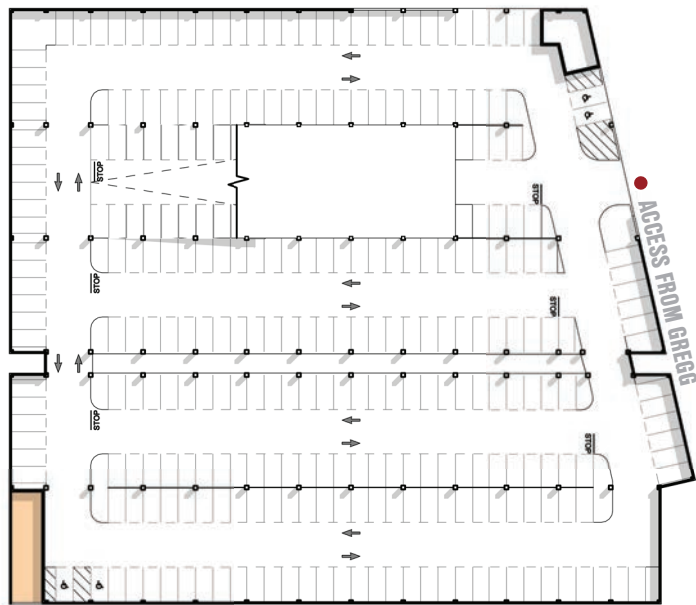

LEVEL 1 - 264 SPACES

LEVEL 2 - 312 SPACES

LEVEL 3 - 308 SPACES

LEVEL 4 - 312 SPACES

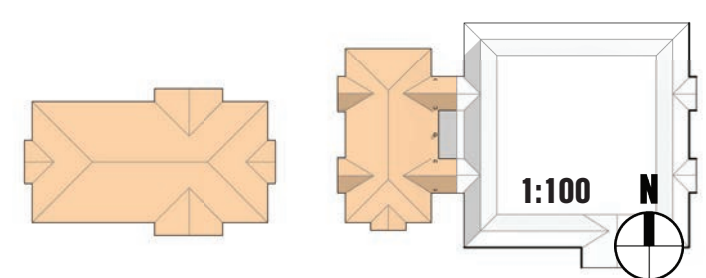
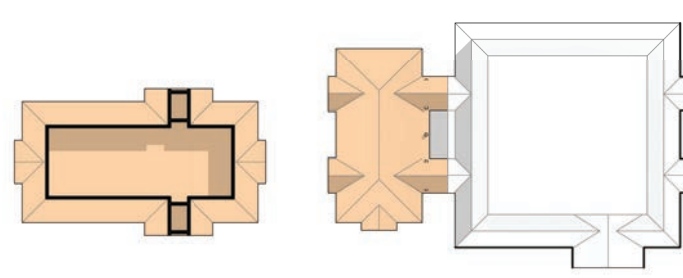
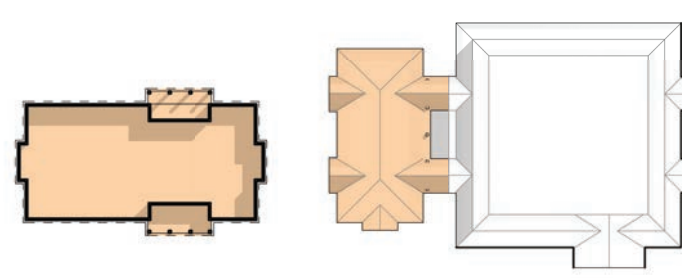
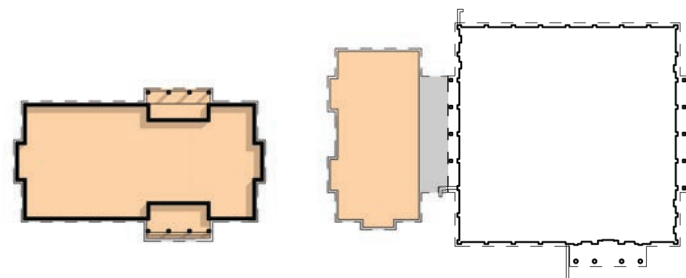
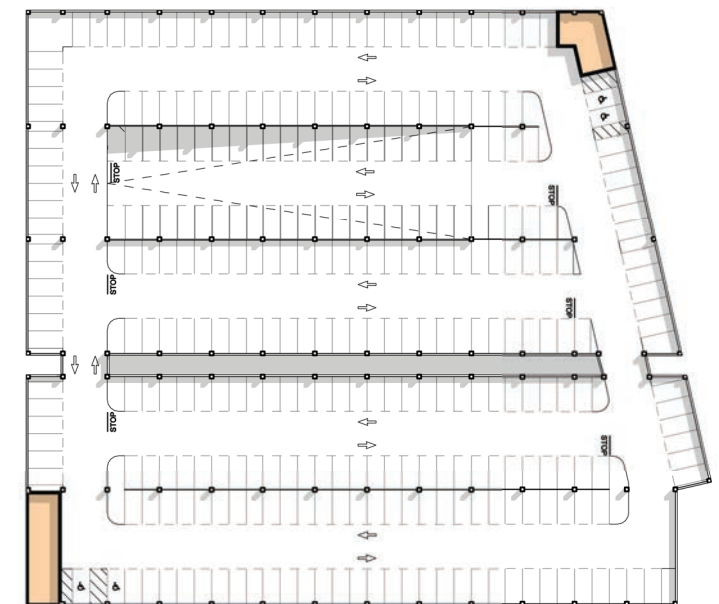
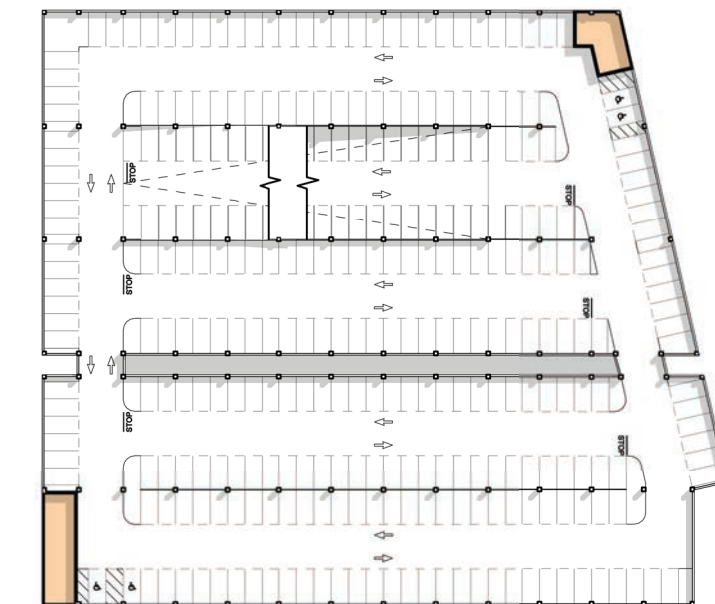
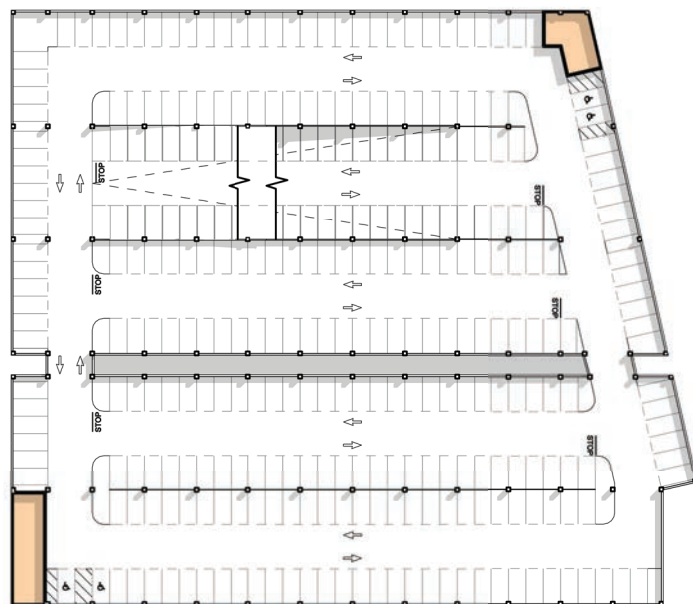
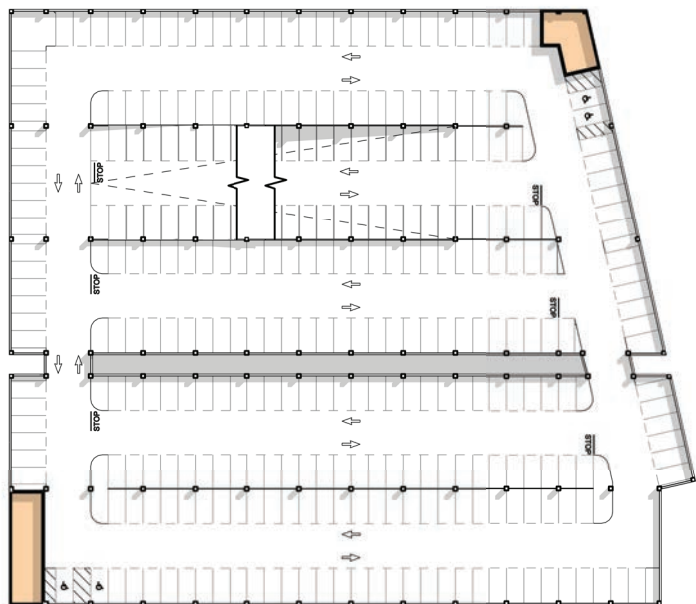

LEVEL 5 - 312 SPACES

LEVEL 6 - 312

LEVEL 7 - 312 SPACES

LEVEL 8 - 312 SPACES

OPTION C

Option C proposes a parking garage with five (5) parking bays running in the east/west direction. The 3 northernmost bays are bisected from the 2 southern bays by a lightwell that is open from top to bottom. A single parking ramp running east/west provides access between levels. While the single ramp may increase vehicular traffic, it is being studied as a cost savings measure by simplifying the other 4 structural bays of the garage. The footprint of this option maximizes the length of parking bays in the east/west by matching the angle of Gregg Avenue and moving closer to edge of curb for both Gregg and Whitham.

The parking is arranged within typical structural bays of 59'-0" x 27'-0". This allows for a slightly reduced two-way drive width of 23'-0" and results in 3 spots per bay. The slight reduction in bay width allows for 5 structural bays to fit comfortably north of the new building on Maple and revised configuration of Sigma Chi.

The garage is striped with 9'-0" wide parking spaces and this results in a range of 1,564 to 2,444 depending on number of parking levels - see Matrix for further detail.

The garage utilizes two individual vehicular access points along Gregg and Whitham subsequently limiting Douglas to pedestrian traffic only across the garage frontage. The access points are distributed as follows:

- Level 1 - Gregg Avenue
- Level 2 - Whitham Avenue

Scull Creek enters the site near the existing storm outlet on Whitham and travels due north until turning east under the primary vehicular drive. Once it reaches the lightwell it moves across the deck open to ventilation, but separated from deck run-off. The creek is then routed into existing stormwater infrastructure underneath Gregg before eventually daylighting northeast of the project limits.



A typical ramp with a length of 189' and a floor to floor height of 11' - 6" results in a slope of 6%.

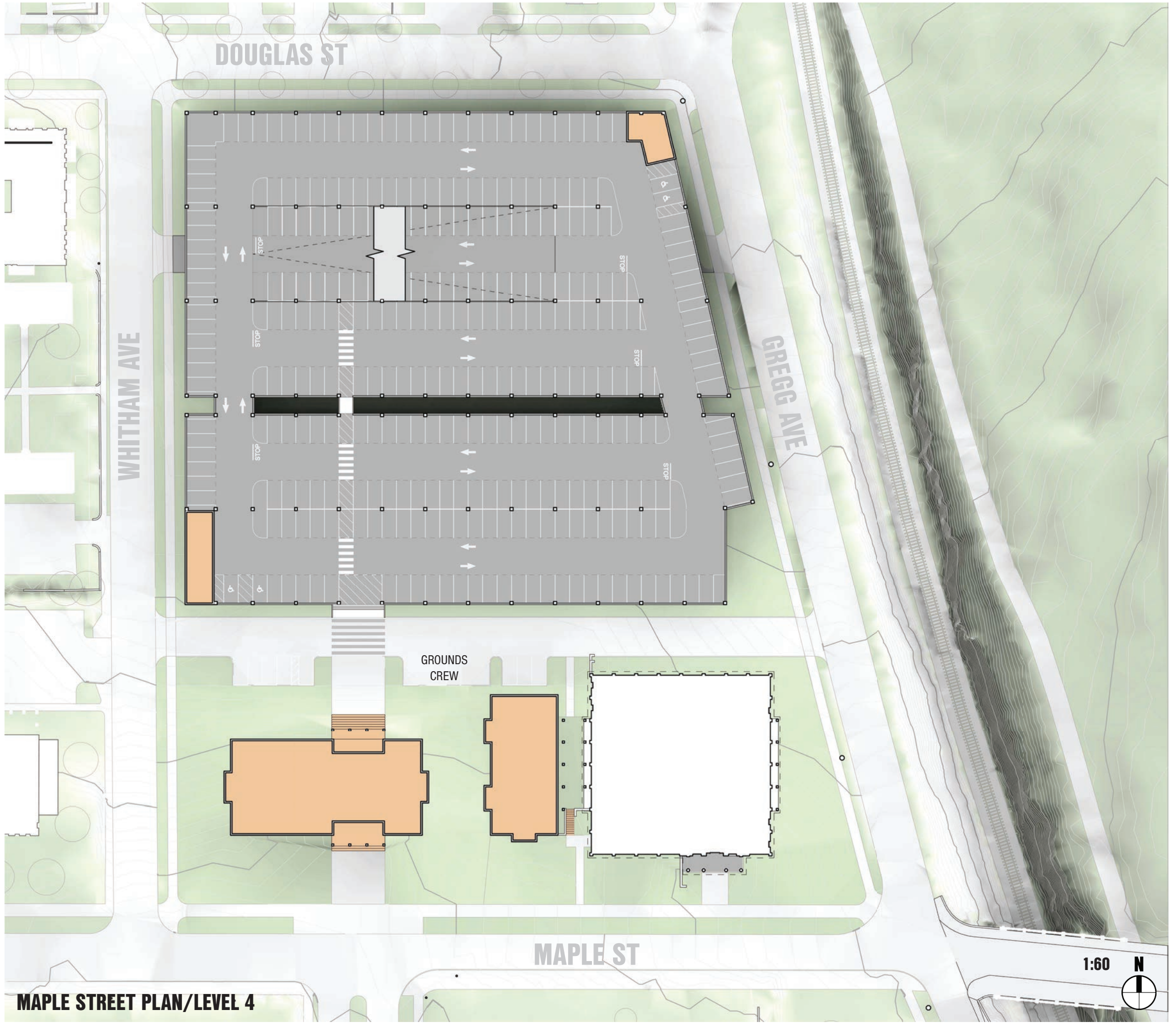
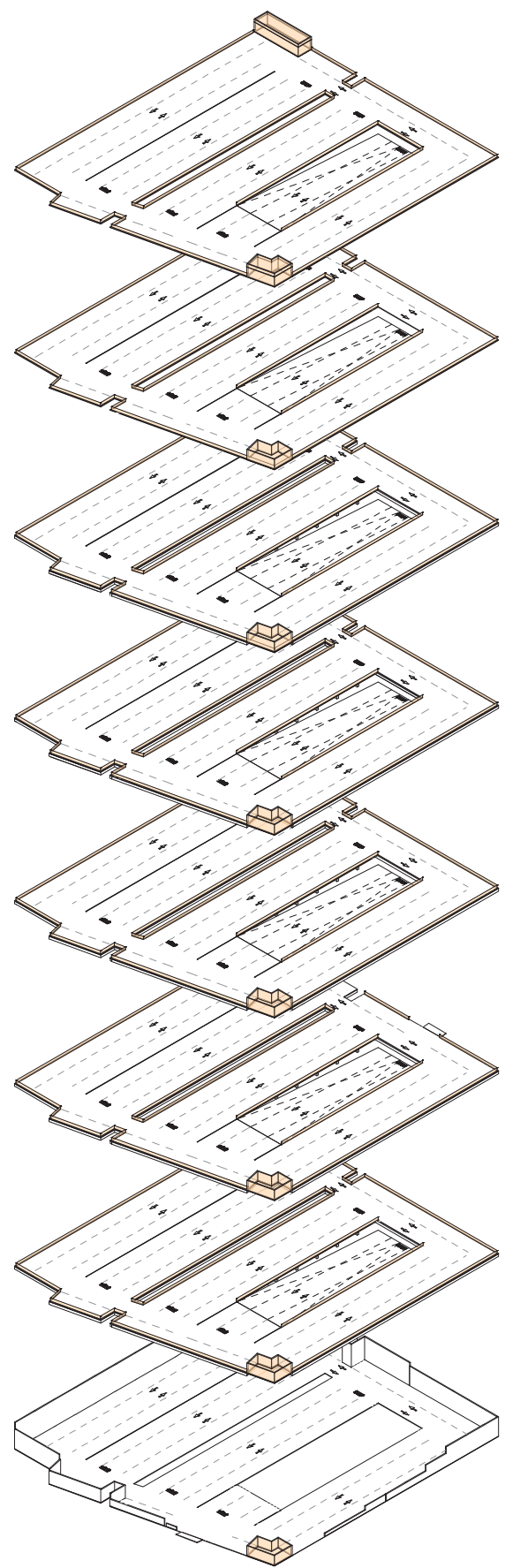

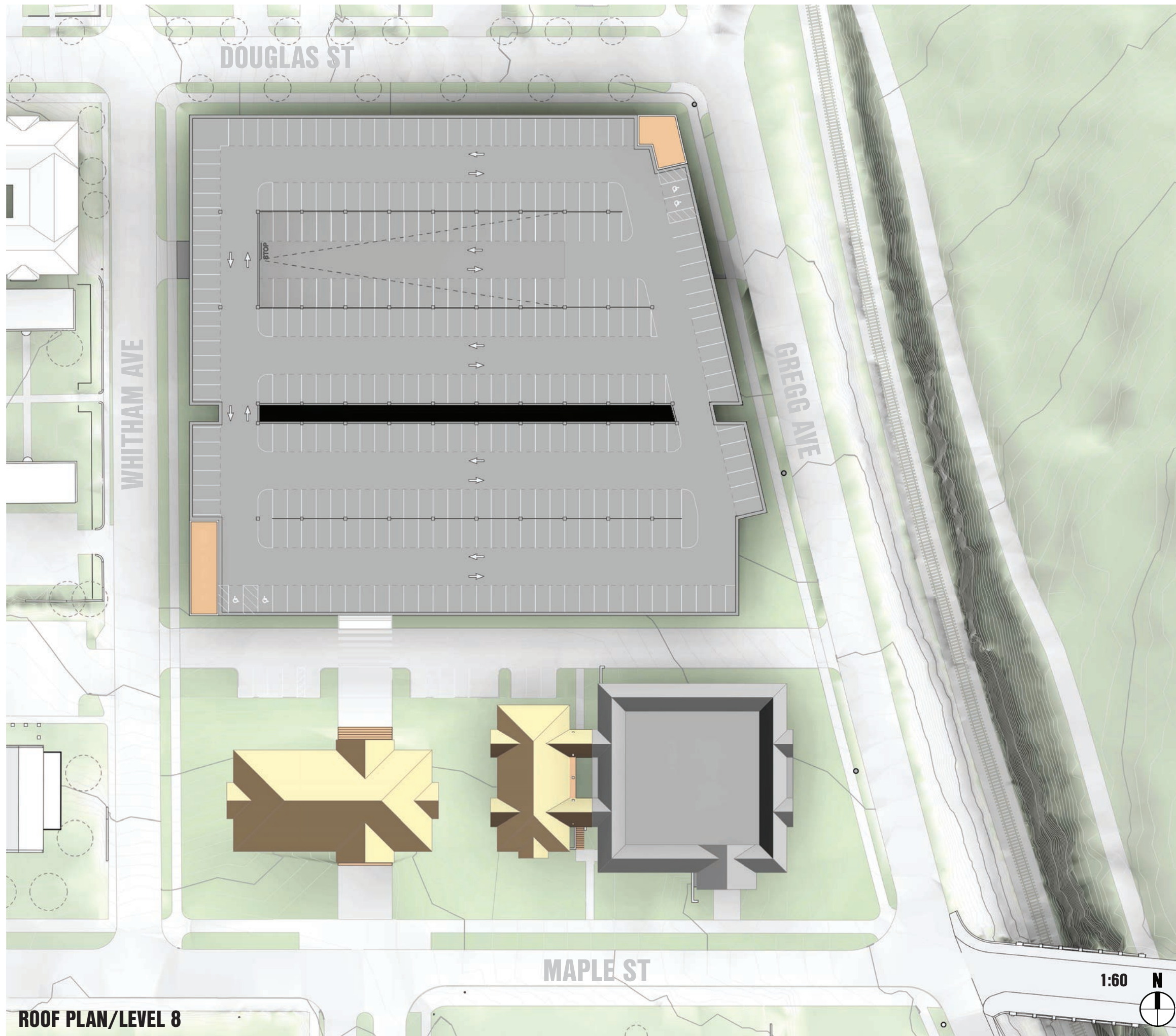

OPTION B (CONT.)

Sigma Chi Fraternity undergoes a fairly substantial modification under this scenario. Under utilized, the Sigma Chi Annex is proposed to be demolished and relocated at a smaller scale fronting Maple. This move allows for a clear division between the garage and Sigma Chi by means of a vehicular alleyway and therefore results in the most efficient parking footprint of the three options presented. The alleyway also provides a serviceable fire lane and provides limited surface parking for the fraternity while eliminating vehicular traffic onto or from Maple Avenue.

A proposed building fronting Maple is shown in as a stand-alone edifice with no structured connection to the garage. It alludes to the most literal interpretation of a traditional structure relating to its surrounding context. The proposed alley does not mix with garage traffic and provides surface parking for the proposed Maple building as well as Sigma Chi.

Option C puts parking count and garage height at Douglas at the top of list and is a good fit if an arrangement for relocating the Sigma Chi Annex can be made.

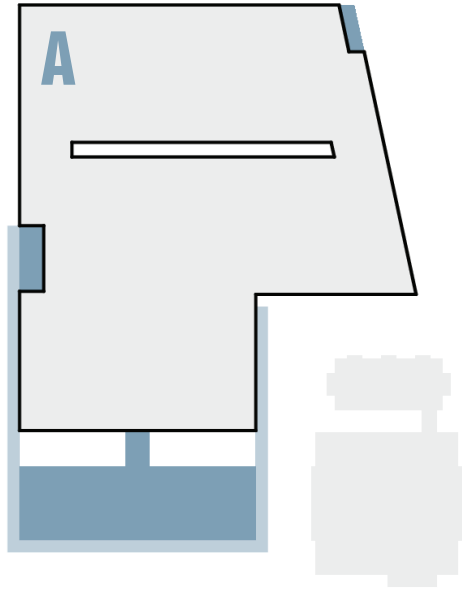

PARKING NUMBERS

OPTION A	FULL EXCAVATION		PARTIAL EXCAVATION	
6 FLOORS	1522	SPACES	1396	SPACES
7 FLOORS	1787		1661	
8 FLOORS	2057		1931	

*parking numbers represent new construction only

TYPICAL BAY

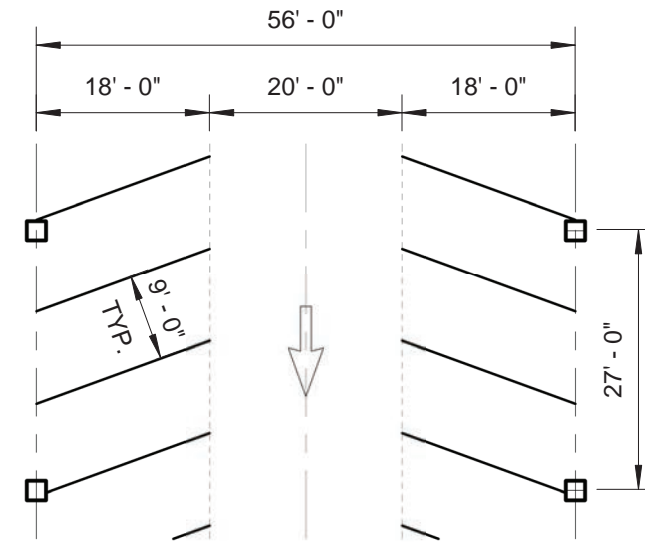

VEHICULAR ACCESS

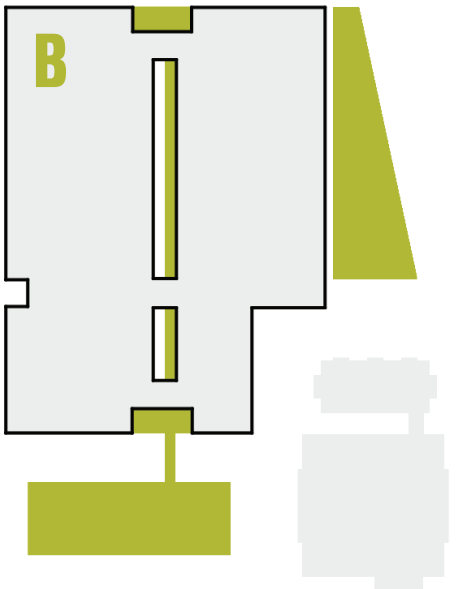
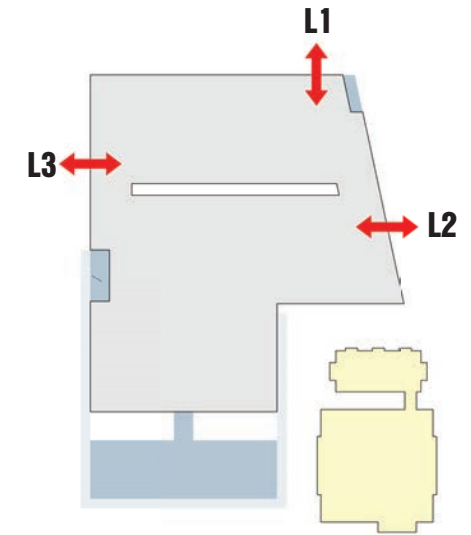

OPTION B	FULL EXCAVATION		PARTIAL EXCAVATION	
6 FLOORS	1290	SPACES	1186	SPACES
7 FLOORS	1516		1412	
8 FLOORS	1742		1638	

*parking numbers represent new construction only

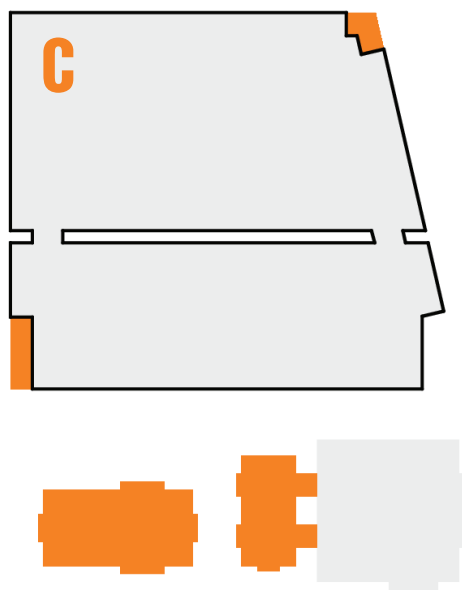
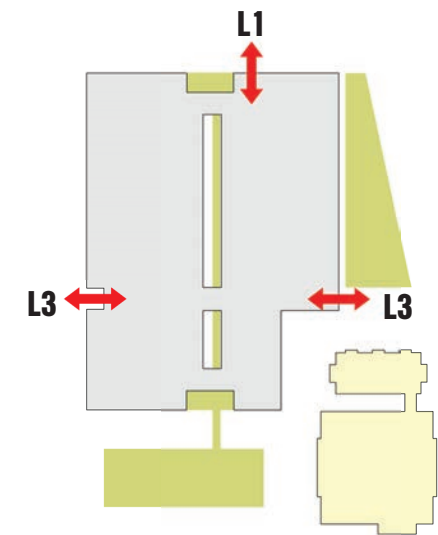
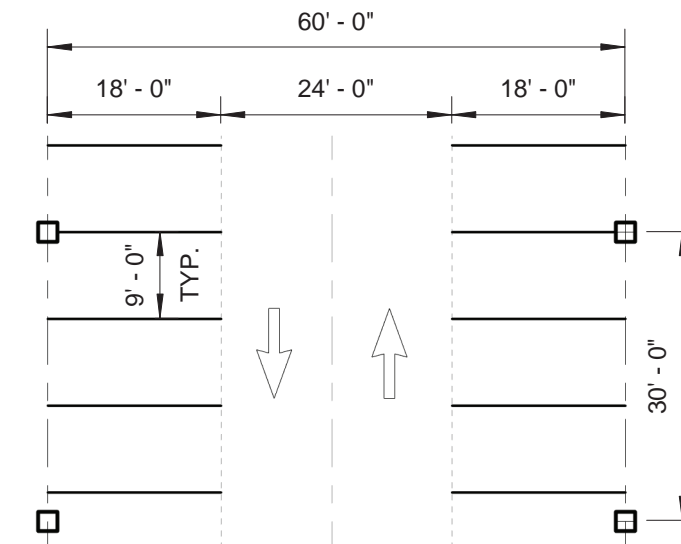

OPTION C	FULL EXCAVATION		PARTIAL EXCAVATION	
6 FLOORS	1820	SPACES	1564	SPACES
7 FLOORS	2132		1876	
8 FLOORS	2444		2188	

*parking numbers represent new construction only

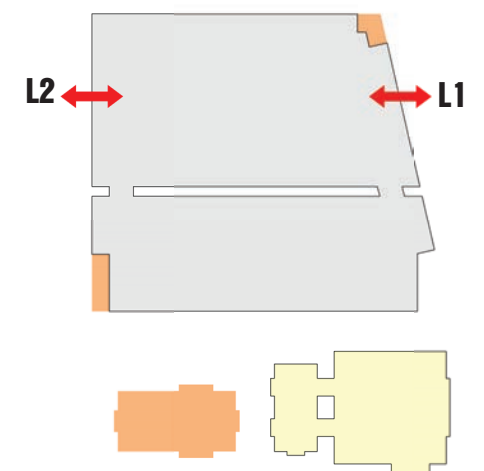
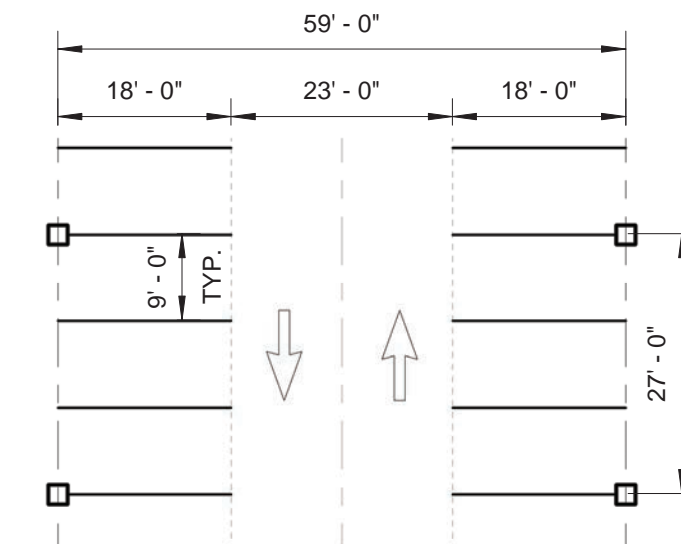

SCULL CREEK

SIGMA CHI

MAPLE FRONTAGE (INTERCHANGEABLE)

MATRIX

PARKING NUMBERS

Ranges for total parking spaces (including required handicap spaces) are shown maxing out at an 8 level garage with full excavation and reducing to a 6 level garage with partial excavation. Recommendations for a preferred option will be addressed in the following section.

TYPICAL BAY

Typical structural bay dimensions are shown as well as identifying traffic direction/flow and parking stall sizes and orientation

VEHICULAR ACCESS

Vehicular access points are diagrammed for each presented option with level of entry/exit identified as well as adjoining street.

SCULL CREEK

Routing of Scull Creek is simplified and illustrated for each presented option showing open air movement in solid blue versus underground routing in dashed blue.

SIGMA CHI

Explained in further detail in the previous descriptions, these diagrams depict the proposed solution for integration of Sigma Chi fraternity and illustrate the flow of vehicular traffic (blue) and pedestrian traffic (orange).

Sigma Chi approximately has 43 bedrooms in the main house and 20 within the annex.

MAPLE FRONTAGE

Proposed options for a new building on Maple are shown in section for each option. As noted earlier, these options are interchangeable and can be applied to A, B, and C with minimal parking modification.

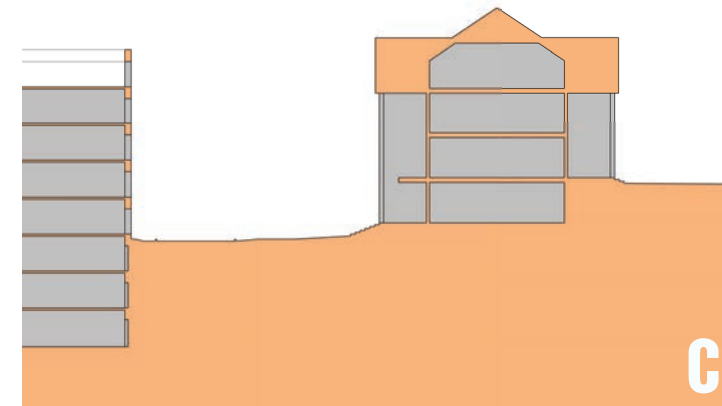
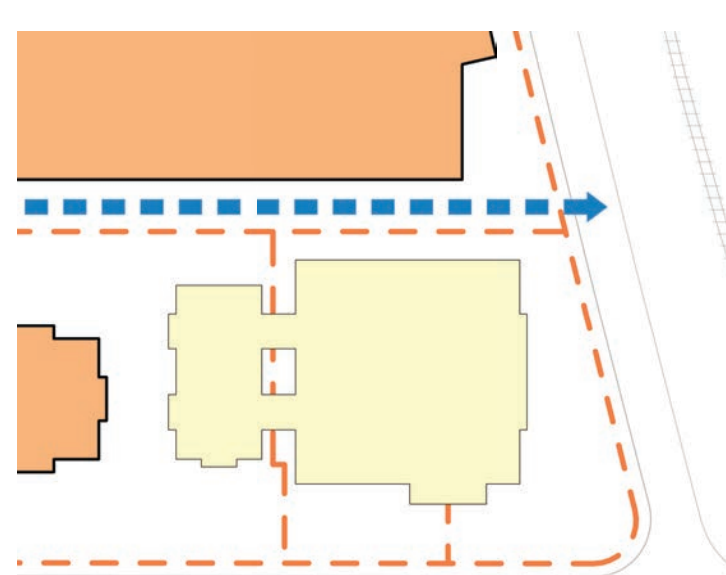
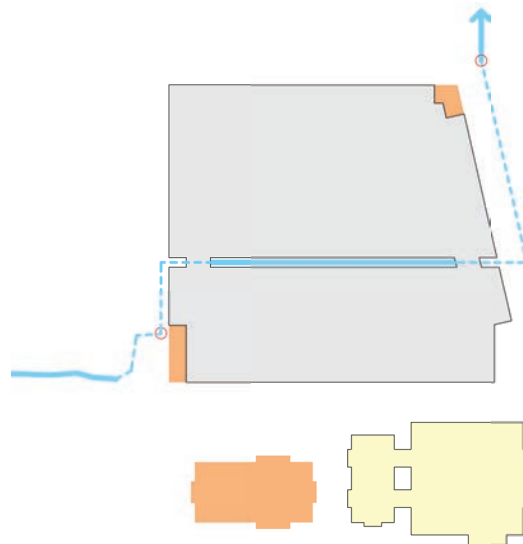
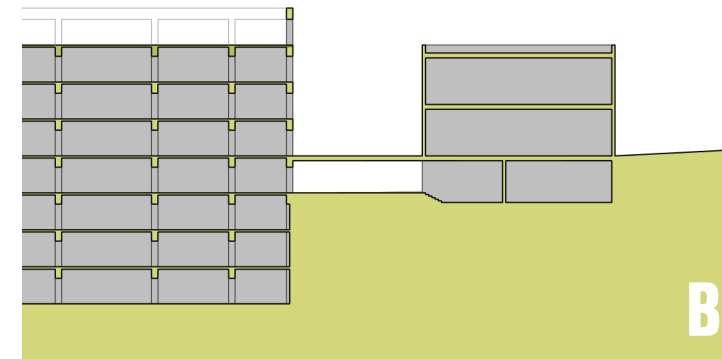
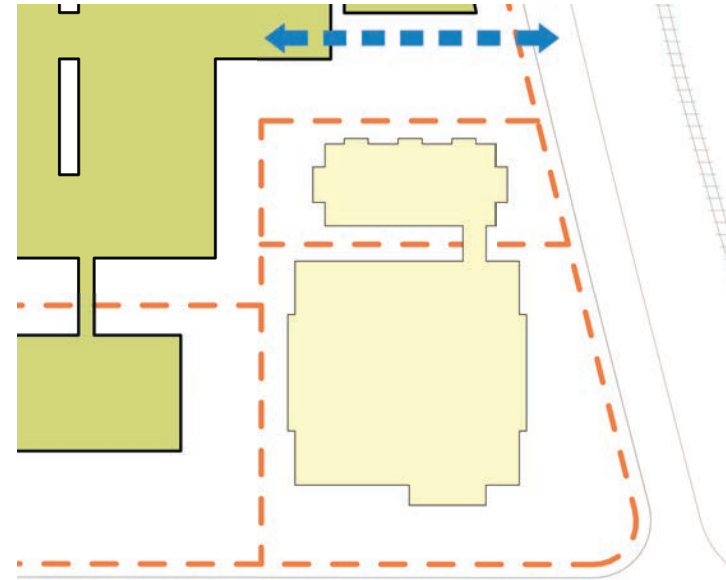
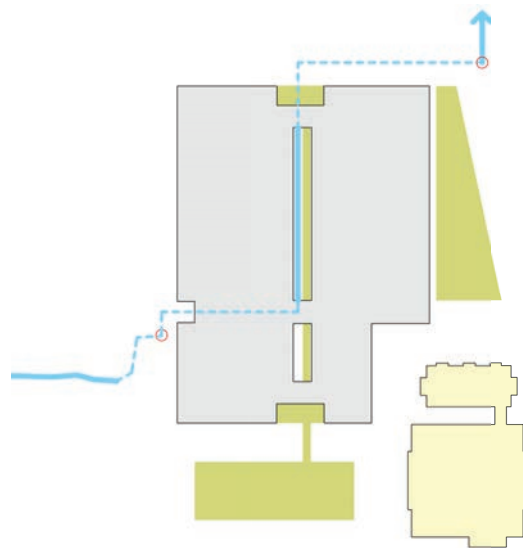
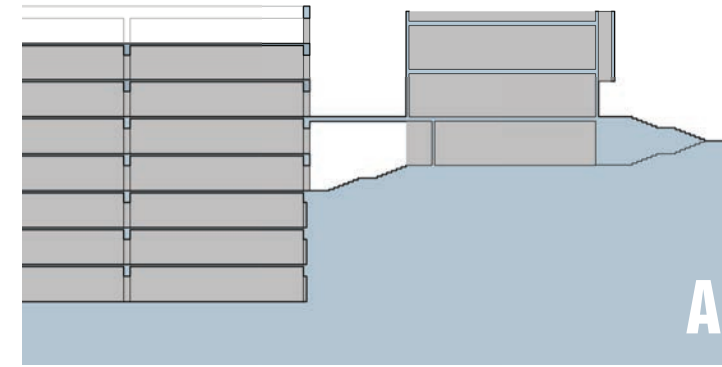
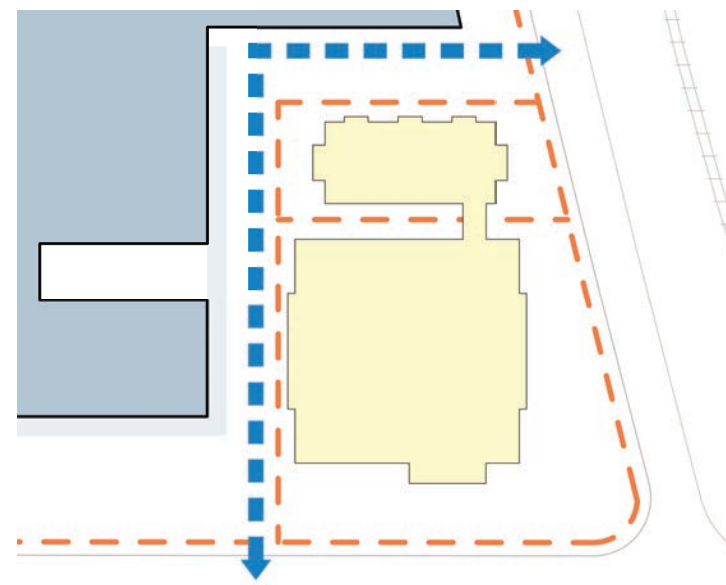
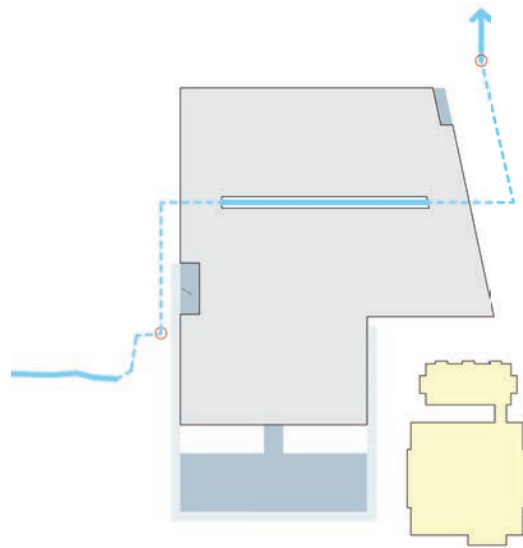

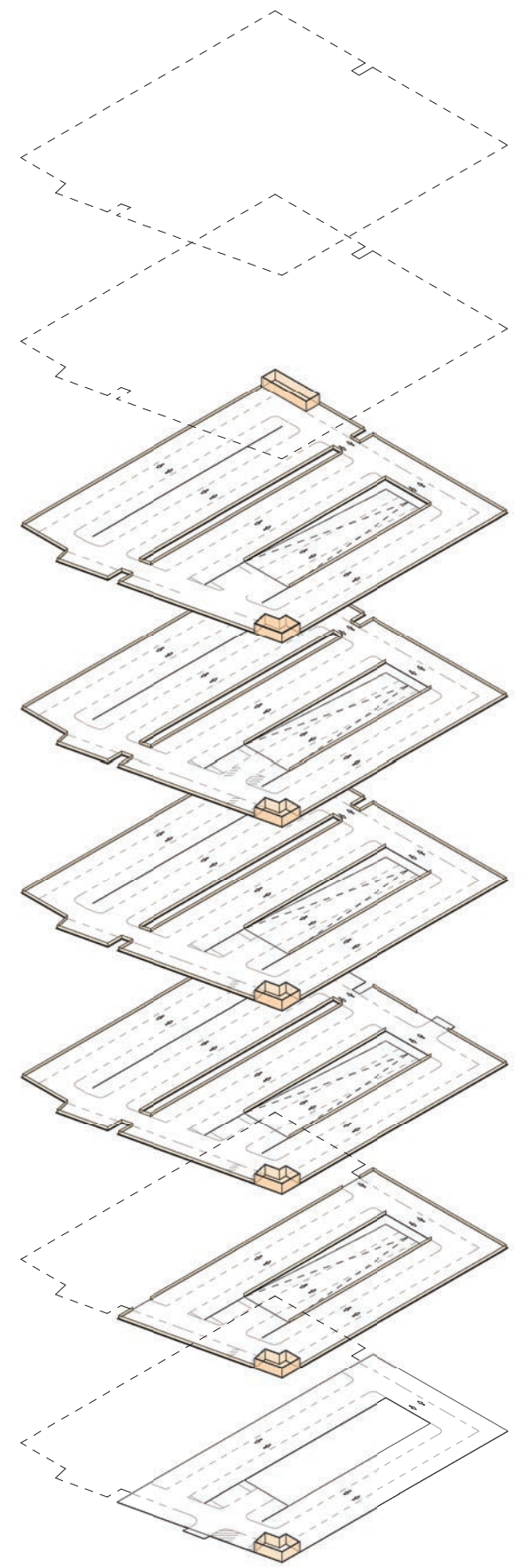
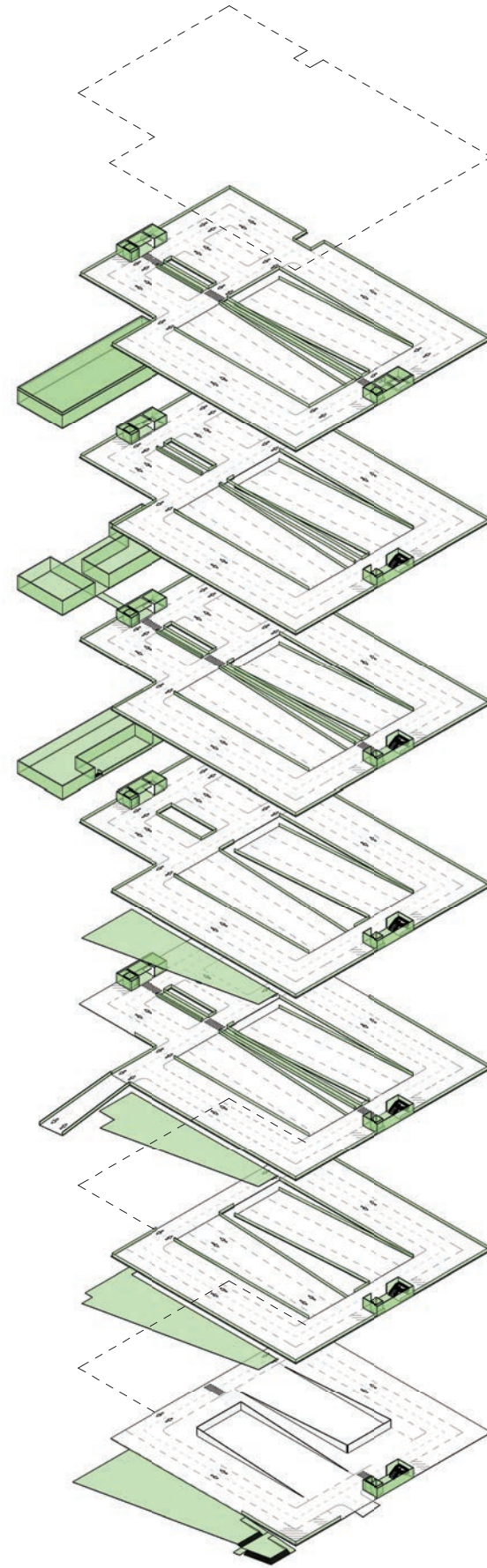
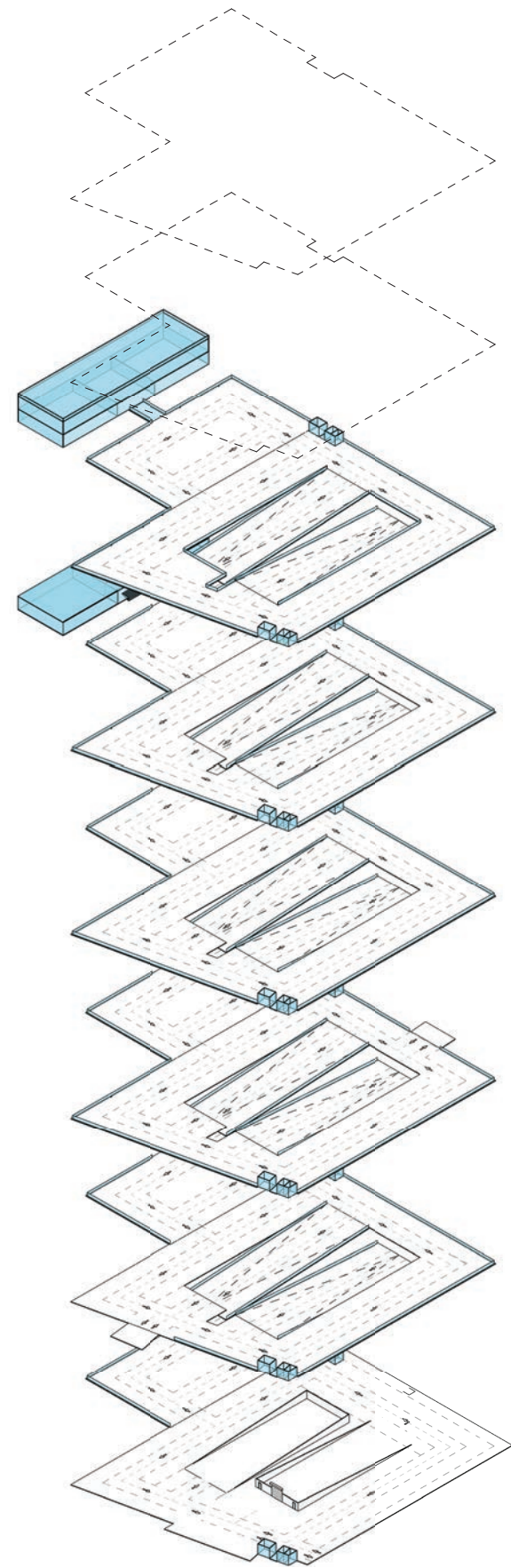

RECOMMENDATIONS

A.1 is a modified version of “Option A” resulting in a garage with a parking capacity of 1,522 spaces. A.1 is the only preferred option to recommend full excavation and achieves this parking count at only 6 levels above Douglas while leaving Sigma Chi intact. Levels 7 and 8 (now omitted) are shown dashed in for reference.

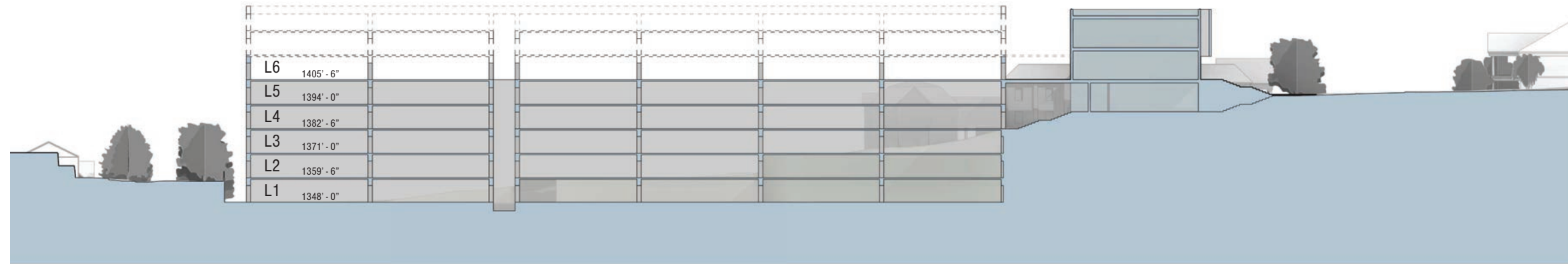
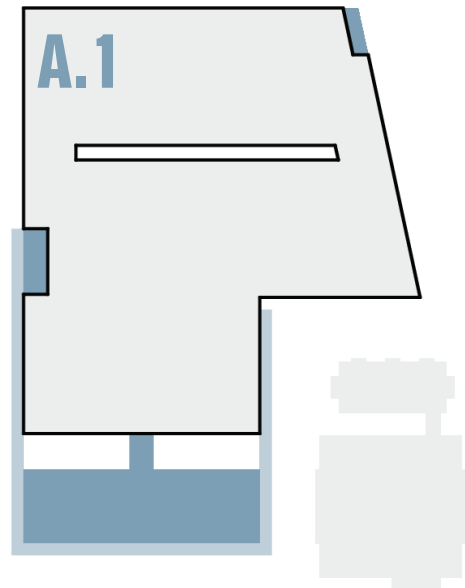

B.1 is a modified version of “Option B” resulting in a garage with a parking capacity of 1,412 spaces. B.1 recommends partial excavation at Levels 1 and 2 and tops out at 7 levels above Douglas. Level 7 as well as the omitted portions of Levels 1 and 2 are shown dashed for reference.

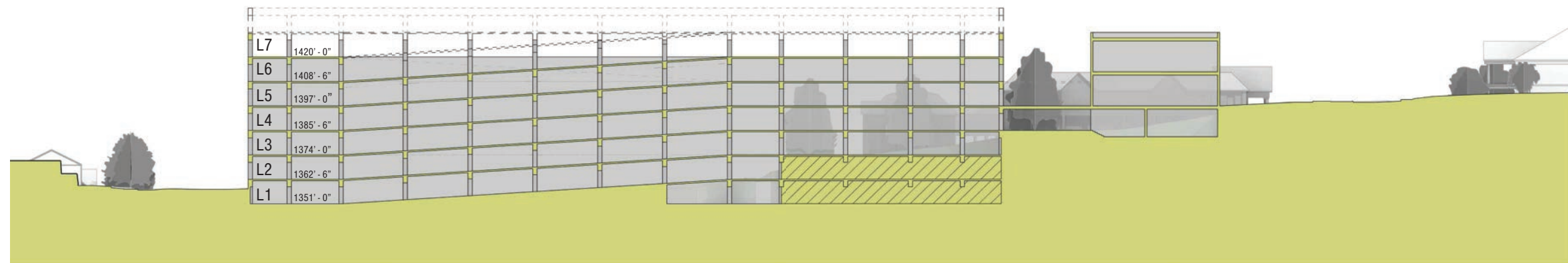
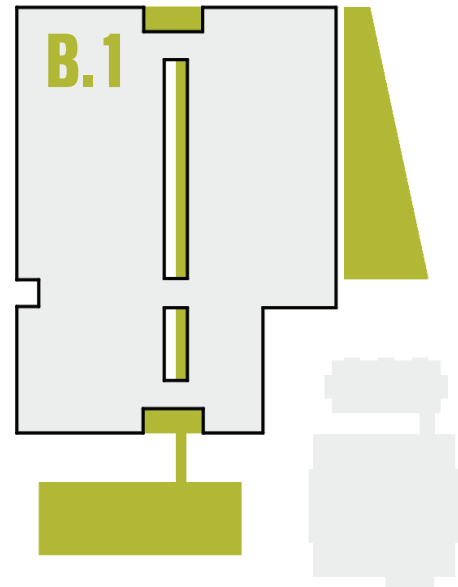

C.1 is a modified version of “Option C” resulting in a garage with a parking capacity of 1,564 spaces. C.1 recommends partial excavation at Levels 1 and 2 and tops out at only 6 levels above Douglas. Levels 7 and 8 as well as the omitted portions of Levels 1 and 2 are shown dashed for reference.

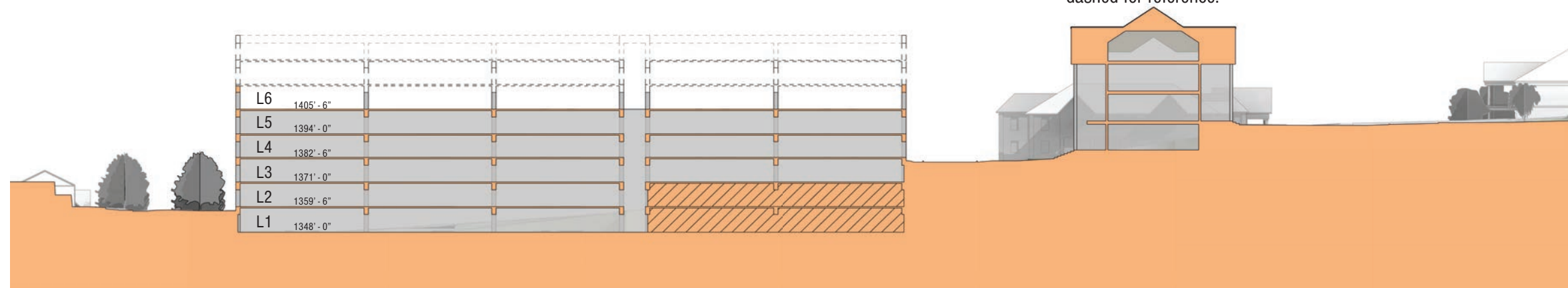
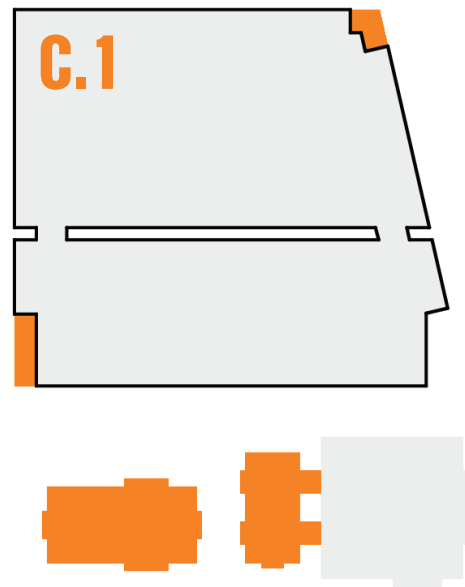

OPTION A.1

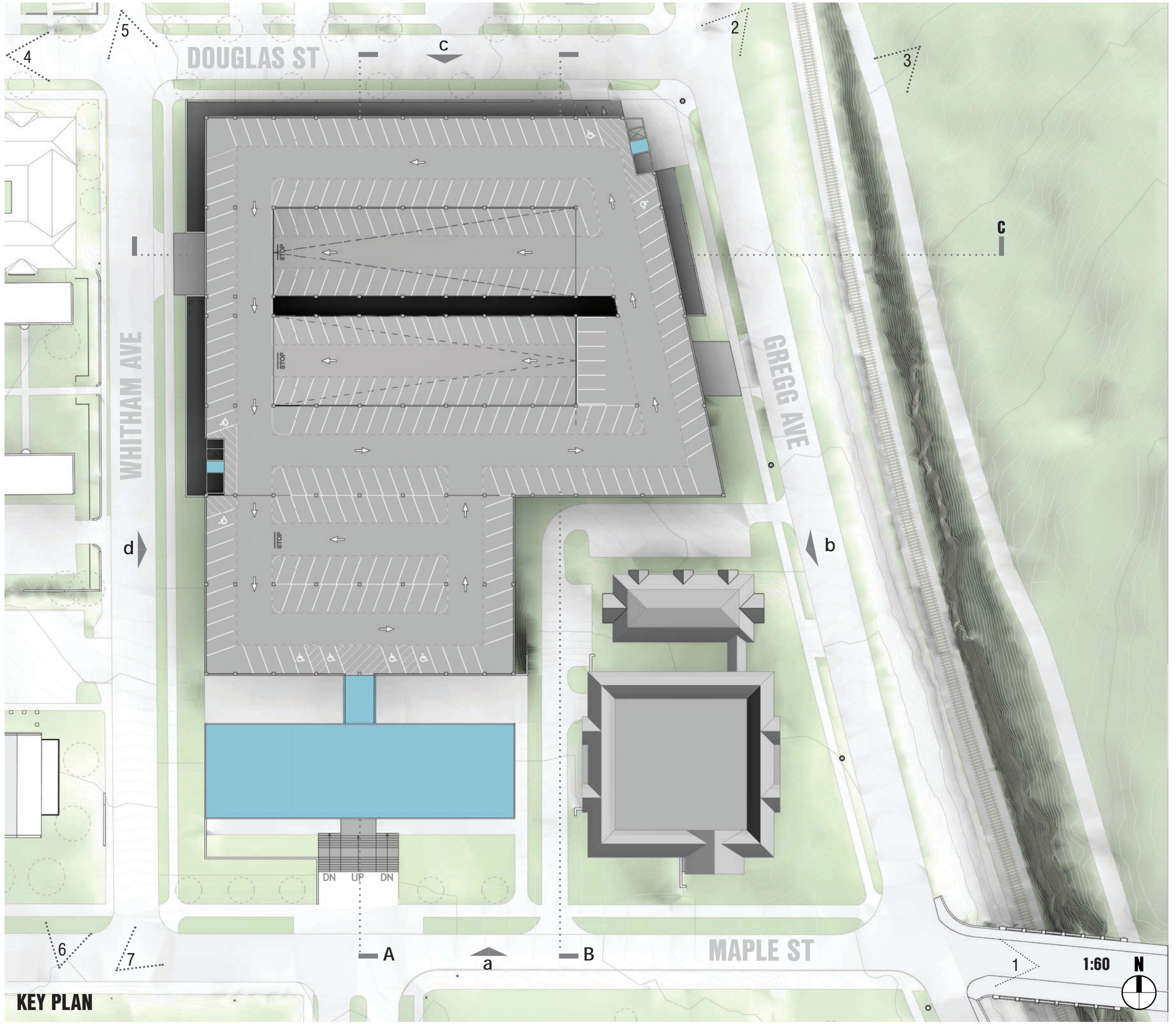
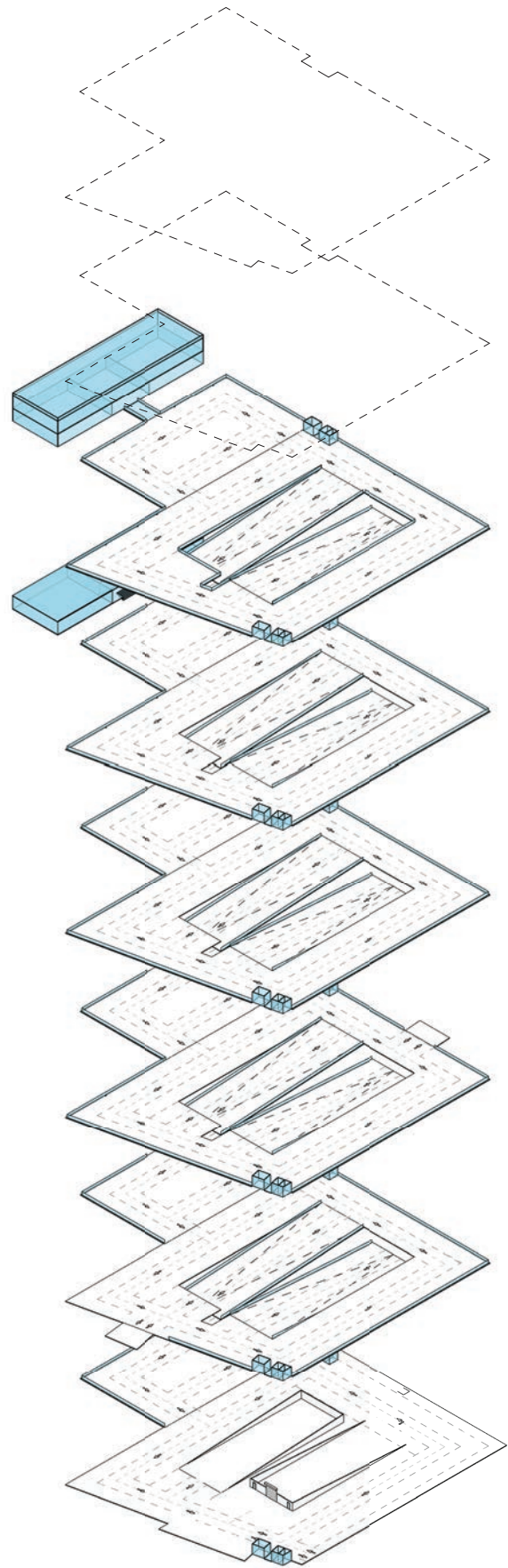

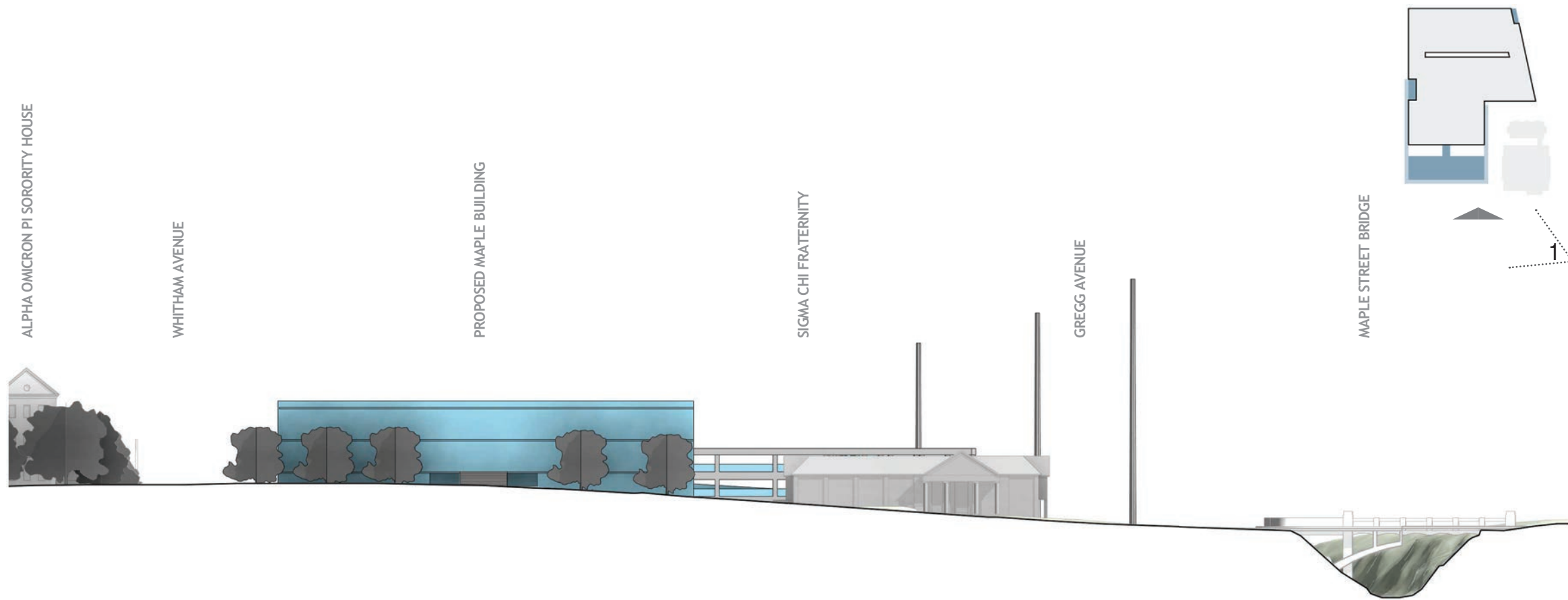

The proposed liner building on Maple aligns its entry porch with the primary axis of Arkansas Avenue. At roughly 2 ½ levels above grade, it begins to mimic the scale and proportion of other structures along Sorority Row.

a. MAPLE STREET ELEVATION

1:60



This view encompasses campus entry at Maple Street Bridge facing west. The proposed Delta Gamma Sorority House can be seen on the left with Sigma Chi Fraternity on the right. The parking garage at 6 levels above Douglas is tucked neatly behind Sigma Chi and the proposed liner building.

1. INTERSECTION OF MAPLE/GREGG

Cut directly through the center of Arkansas Avenue, this section shows the relationship of the garage to the proposed liner building. A pedestrian bridge connects Maple street level to the garage at Level 6, while the lower level of the liner building steps down to communicate with Level 4.

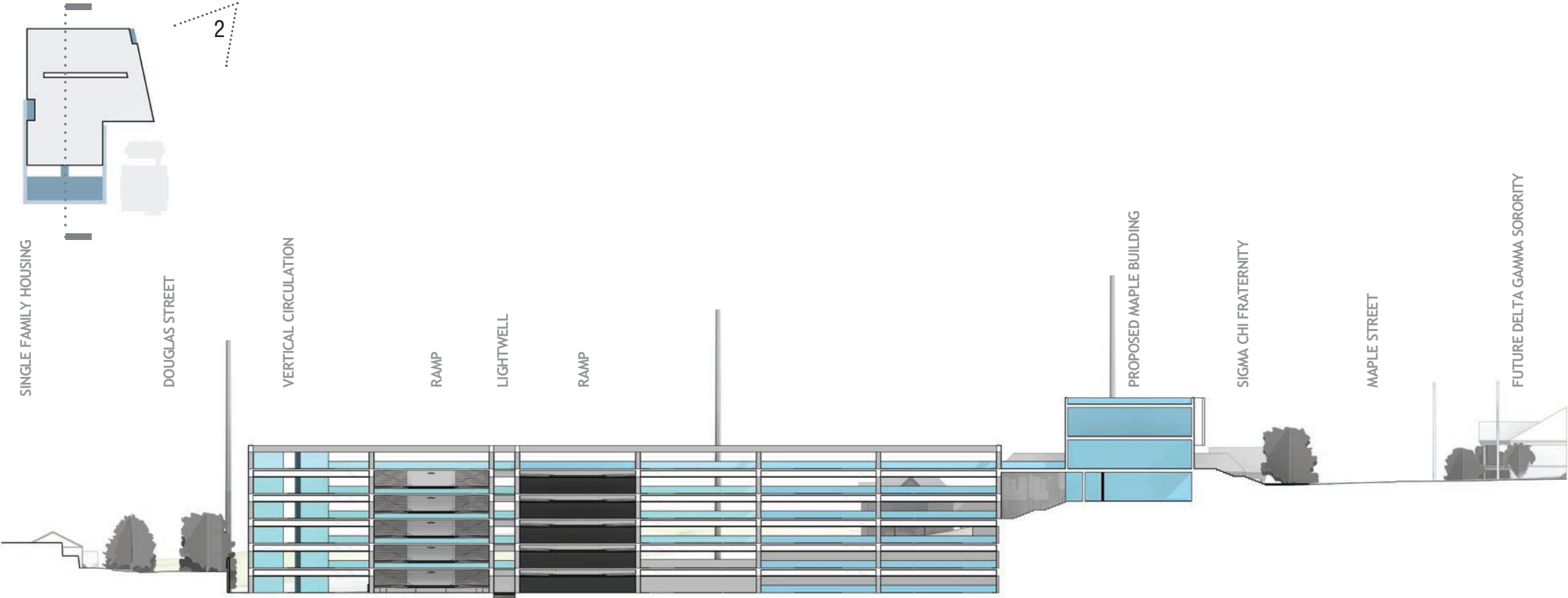

SECTION A

1:60

The view looking south along Gregg Avenue would be the approach coming from Frisco Trail. Vertical circulation at this corner of the garage would be advantageous for trail patrons who are making their way onto campus.

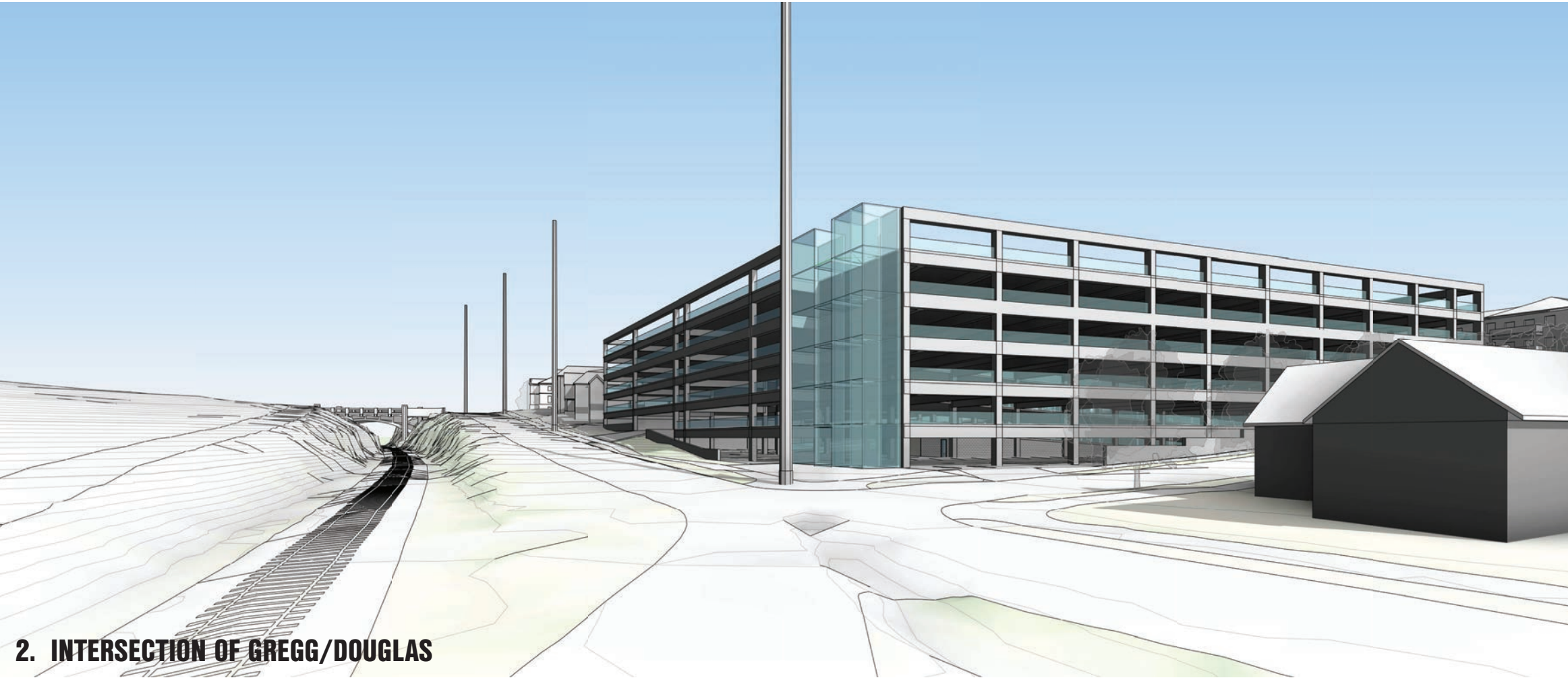

2. INTERSECTION OF GREGG/DOUGLAS

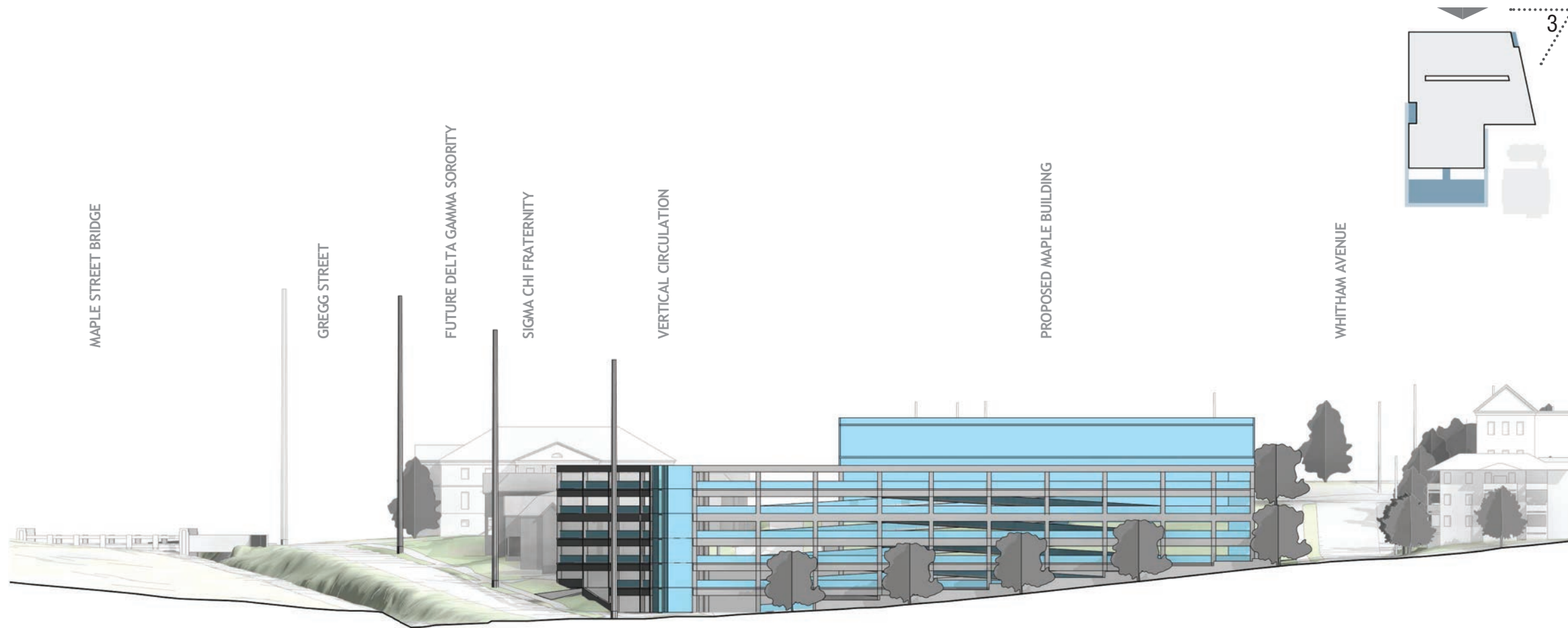

The street elevation at Douglas captures the surrounding Greek buildings beyond. The proposed garage remains below the crown of the roof of all surrounding context.

c. DOUGLAS STREET ELEVATION

1:60

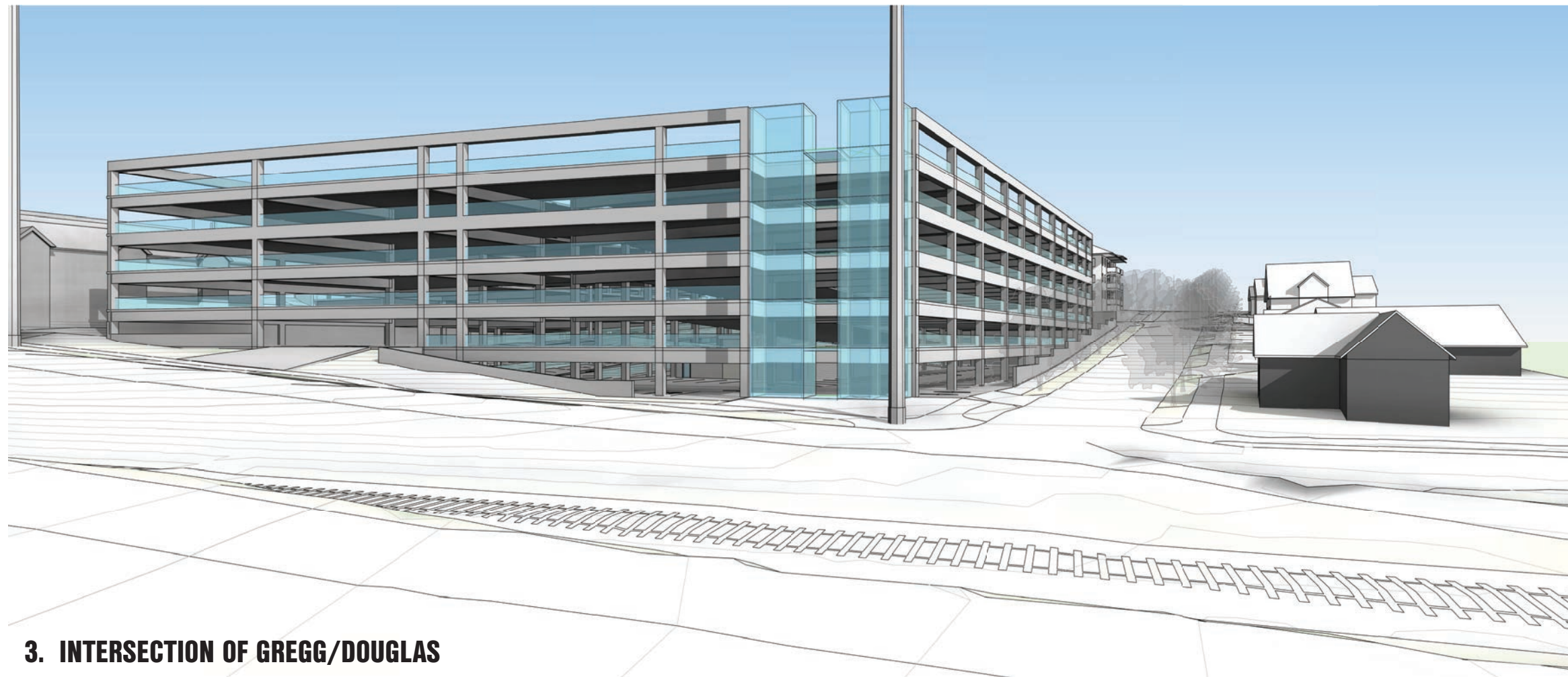

The northeast corner of the garage will appear tallest here due to existing grade. Contextually, the garage is not a good match for the single-family residences along Douglas. Facade screening could be implemented to break up the facade in scale and better relate to the residential housing. Future development along Douglas might consider the scale and proportion of the 3 story multi-family residential seen in the distance on the corner of Whitham and Douglas.

3. INTERSECTION OF GREGG/DOUGLAS

A section cut further east shows the correlation of the proposed garage in relation to the Sigma Chi House. Also shown is the disproportionate relationship between a garage of any substantial height and houses along Douglas.

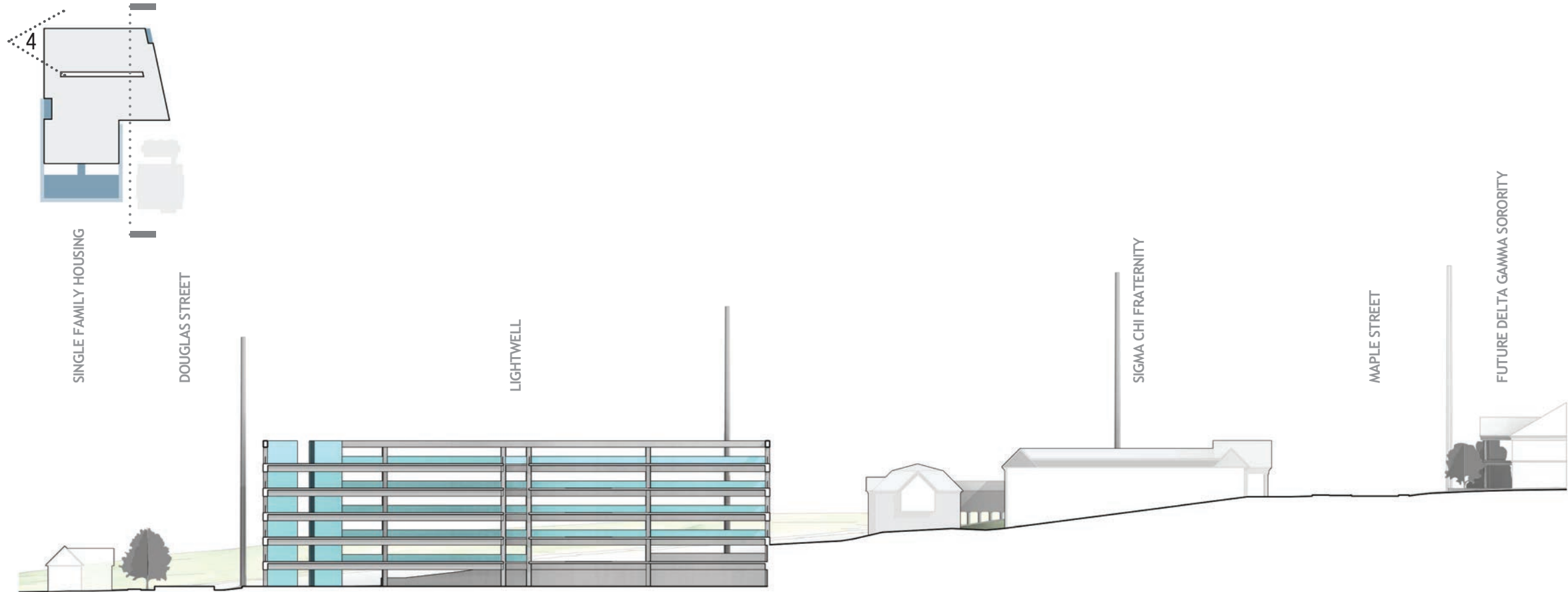

SECTION B

1:60

A view looking east along Douglas begins to show the similarity in scale between the multi-family housing and the parking garage with 2 levels below grade at Whitham.



4. INTERSECTION OF DOUGLAS/WHITHAM

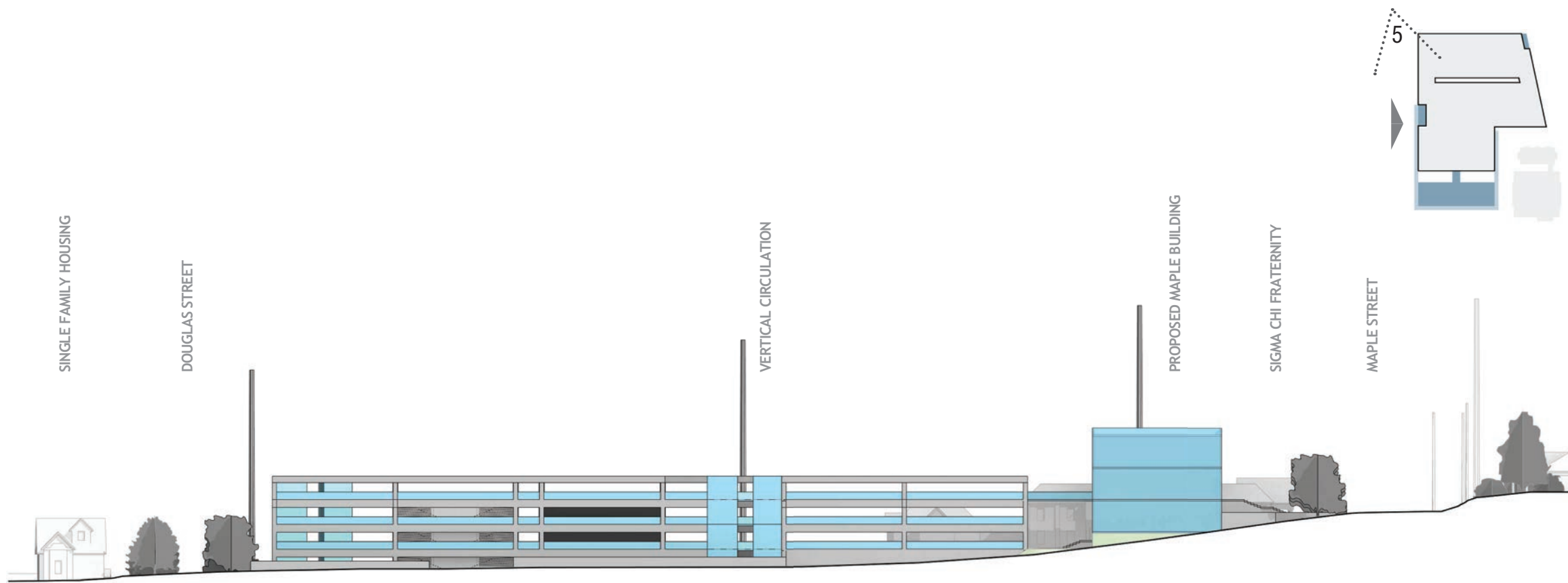

The garage takes advantage of the minimal slopes along Whitham aligning with Level 3 of the garage for a majority of the façade. Just south of the vertical circulation, the existing grade makes a quick transition up to Maple allowing for a building that sits well above the limits of the garage.

d. WHITHAM AVENUE ELEVATION

1:60

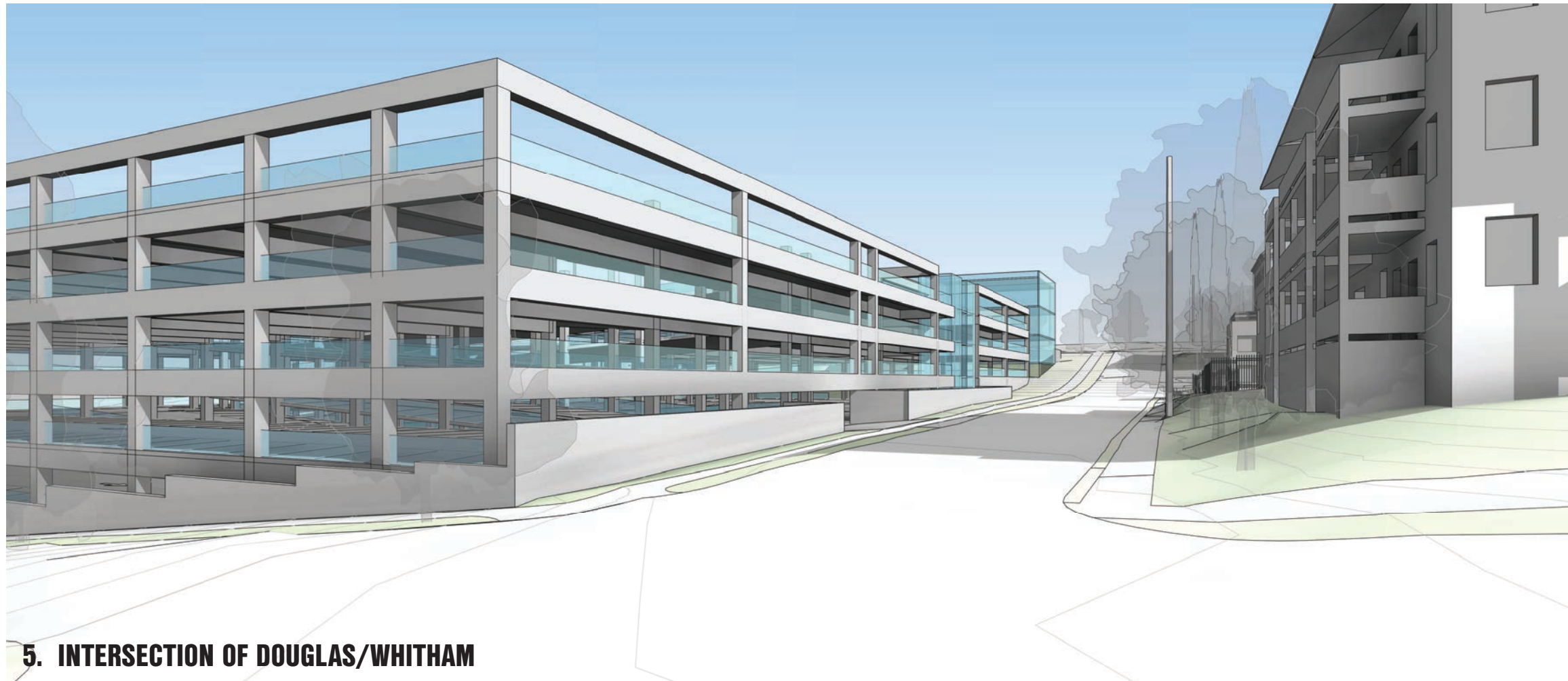

A view looking south along Whitham further enforces the preferred streetscape of two closely proportioned structures on either side of a pedestrian friendly city street.

5. INTERSECTION OF DOUGLAS/WHITHAM

A cross section through the north parking ramp shows a Level 3 entry point off of Whitham taking traffic immediately up to Level 4 and the remaining upper levels of the garage.

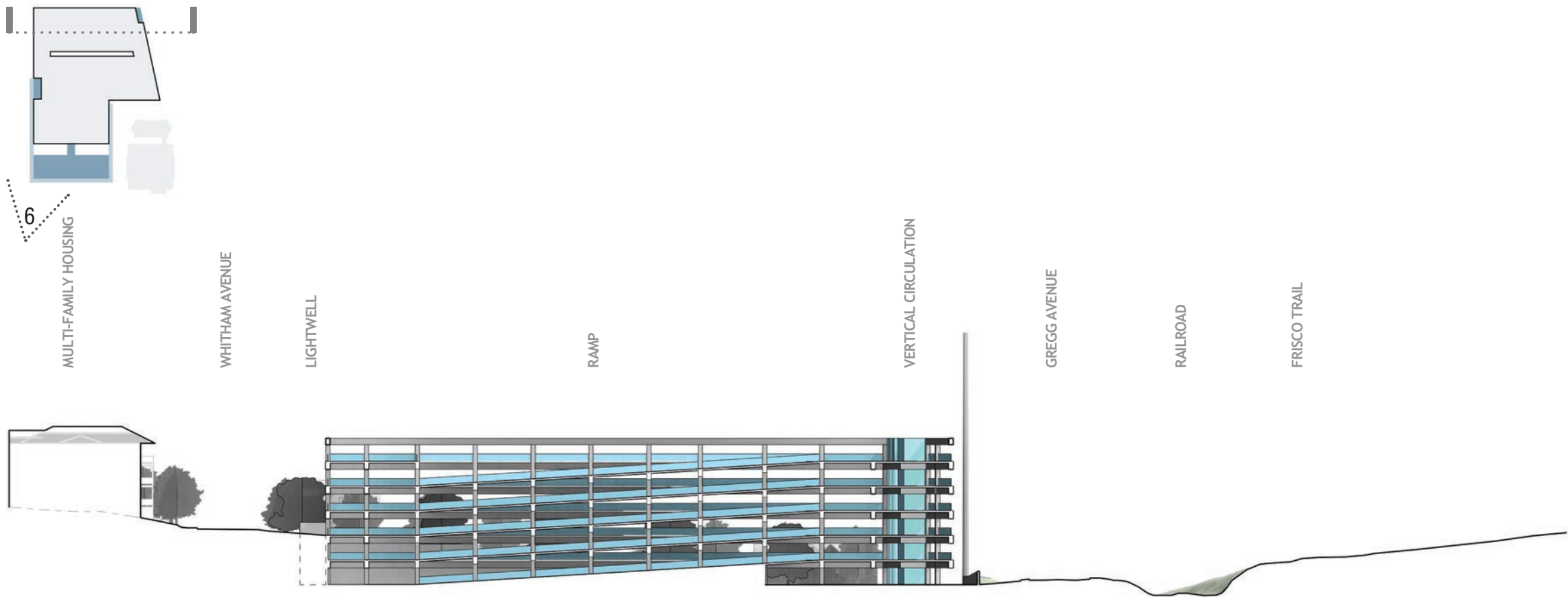

SECTION C

1:60

The height of the proposed building along Maple is a direct nod to the scale and proportion of the neighboring Alpha Omicron Pi House. As the garage makes its transition into the hillside, the relationship to the multi-family housing can be seen in the distance.

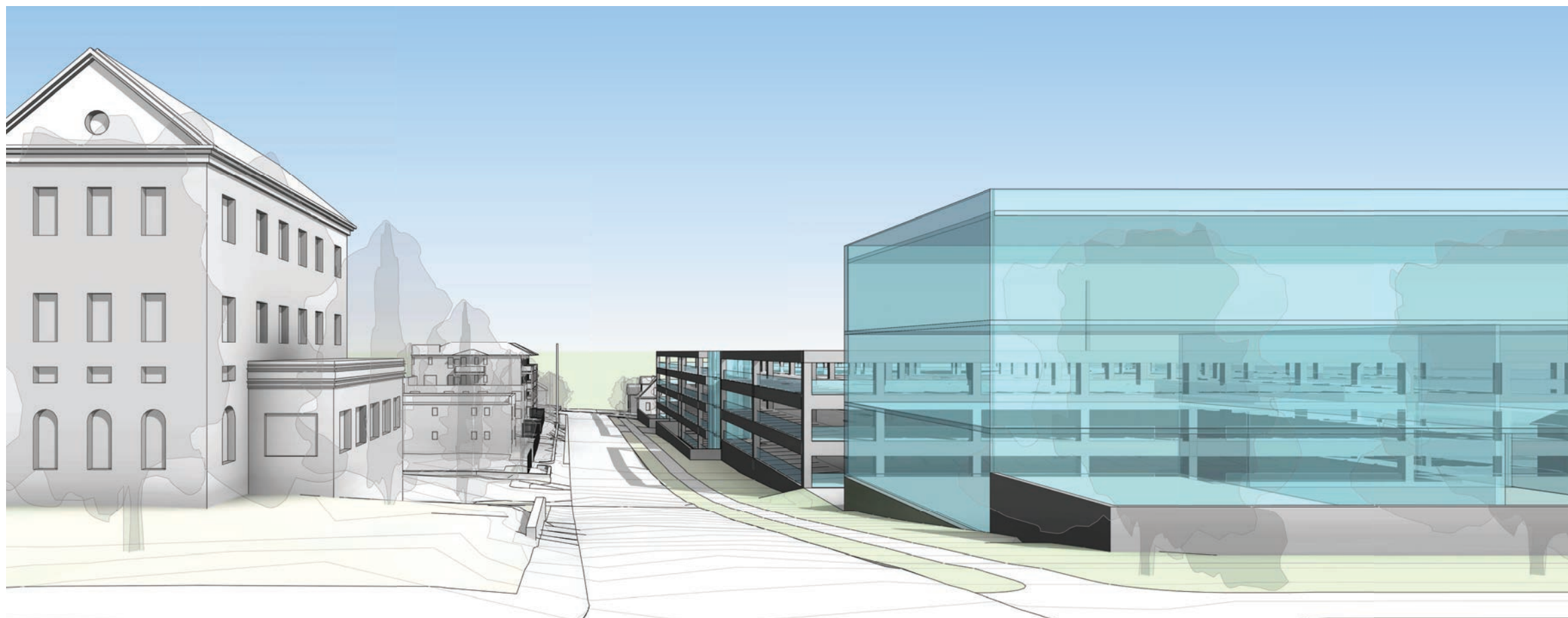

6. INTERSECTION OF WHITHAM/MAPLE

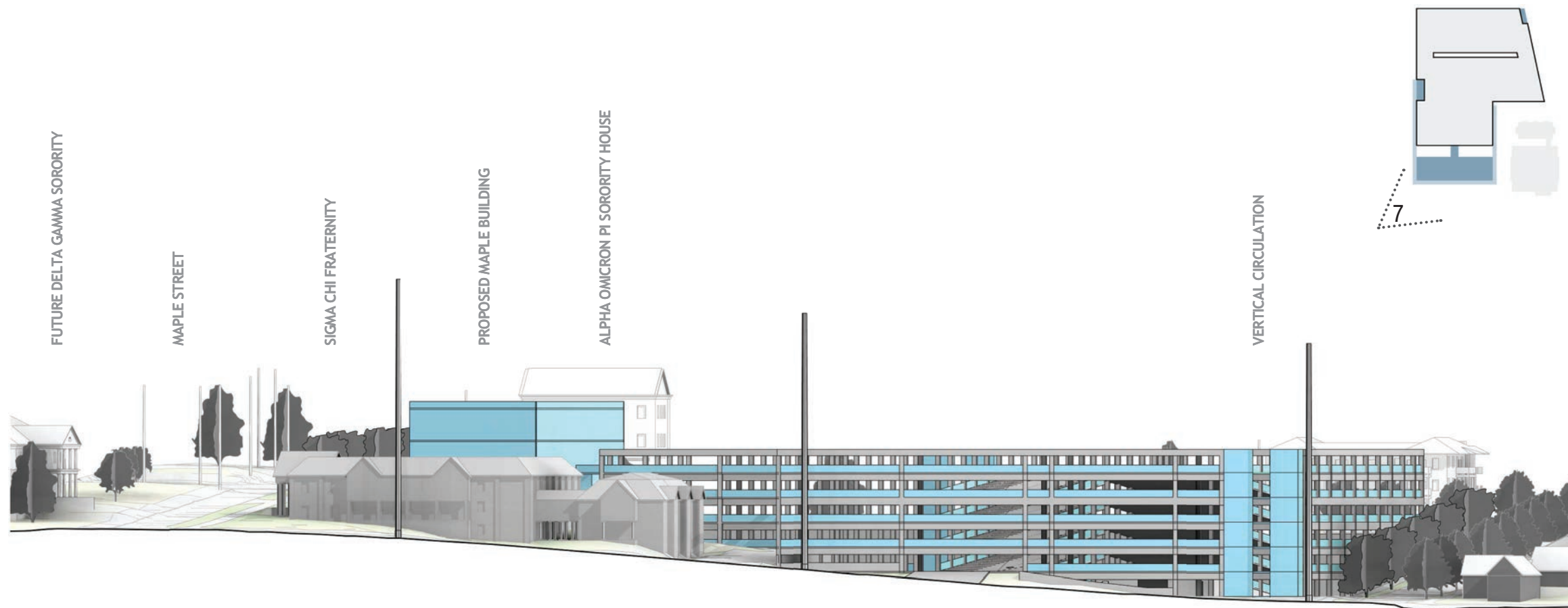

A street elevation along Gregg Avenue shows a steady drop in grade from south to north. While this does allow the garage to sit much lower in relation to Maple Street, it could make entry/exit along Gregg difficult without slight modifications to the street.

b. GREGG AVENUE ELEVATION

1:60

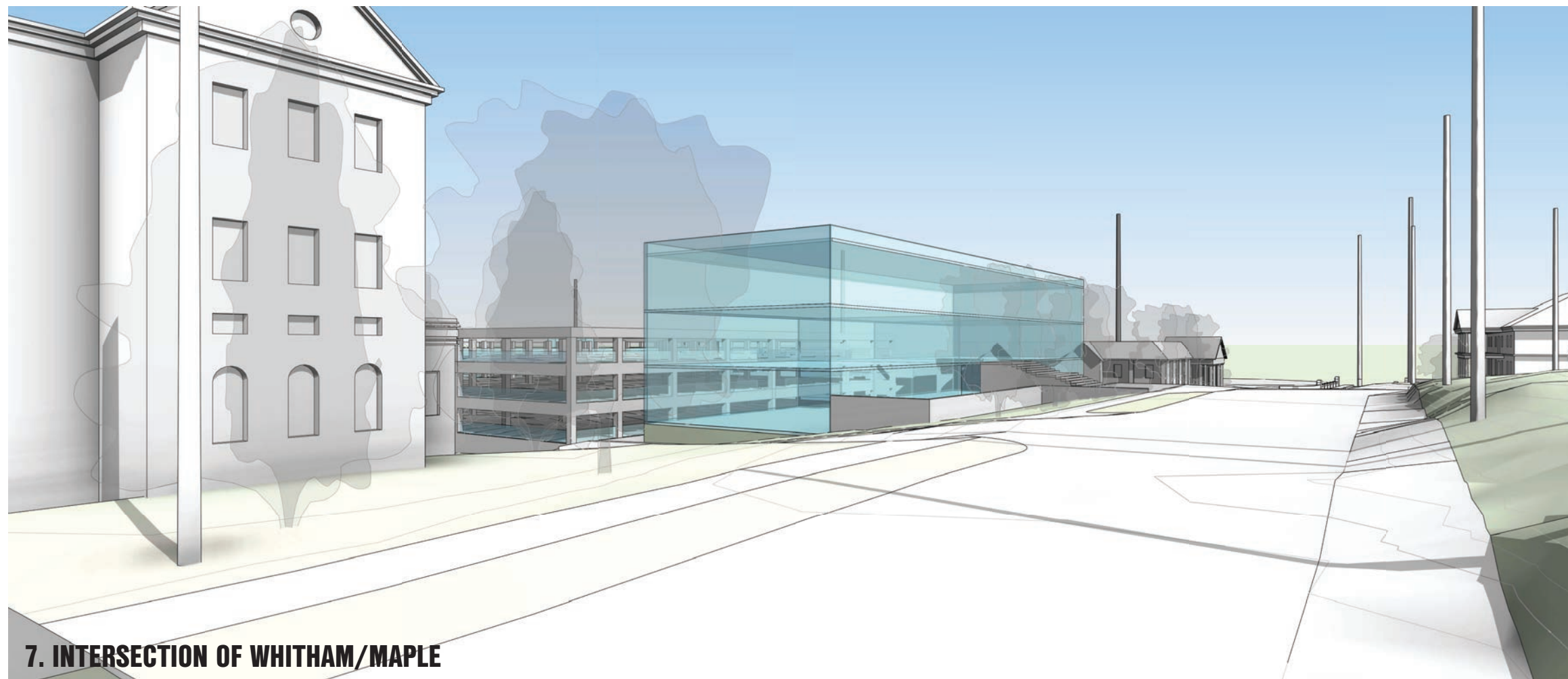

The proportion and scale of any proposed structure along Maple should be a careful balance between Alpha Omicron Pi to the west and Sigma Chi to the east. Also of note is the proposed Delta Gamma house on the south side of Maple.

7. INTERSECTION OF WHITHAM/MAPLE

OPTION B.1

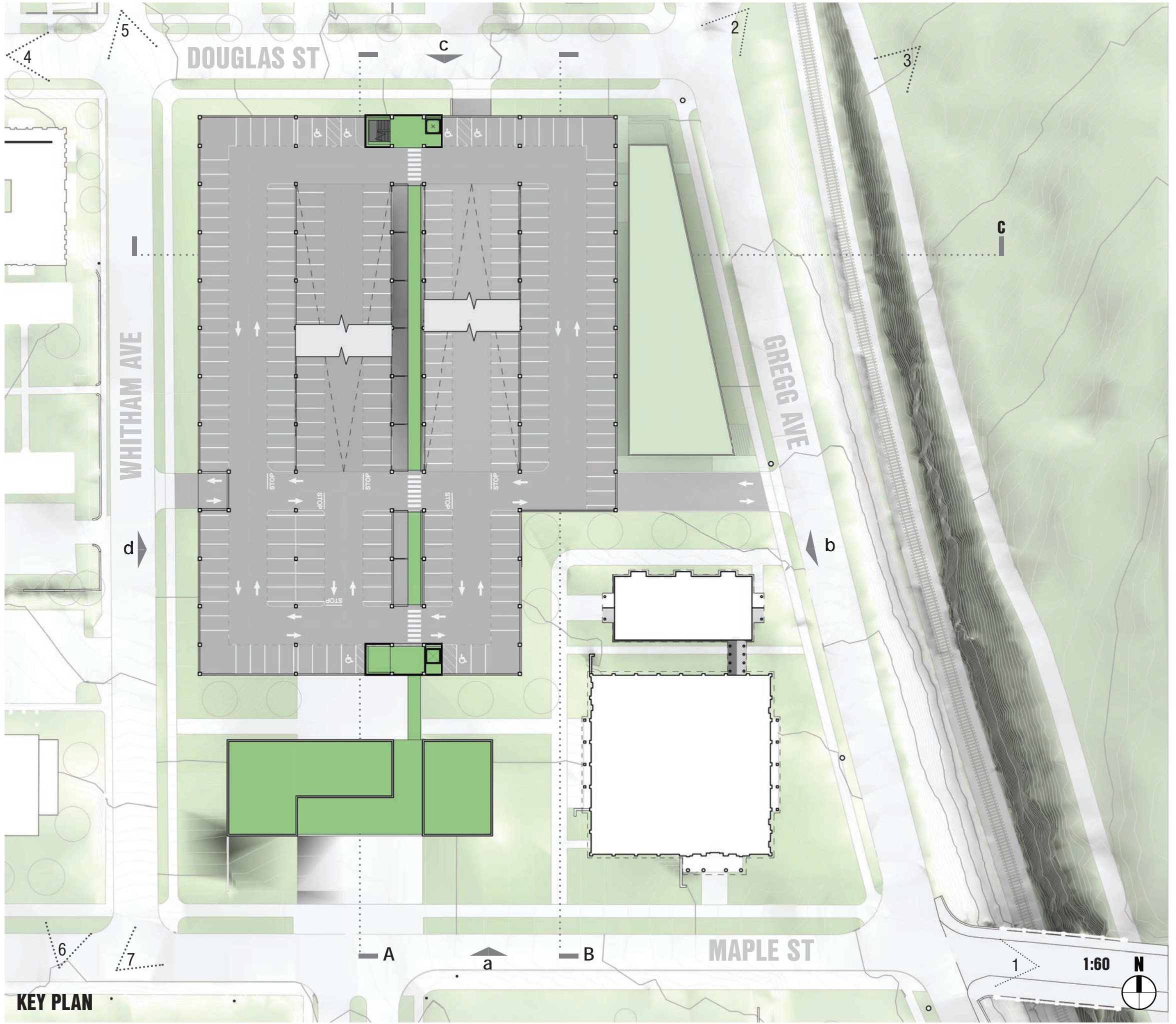
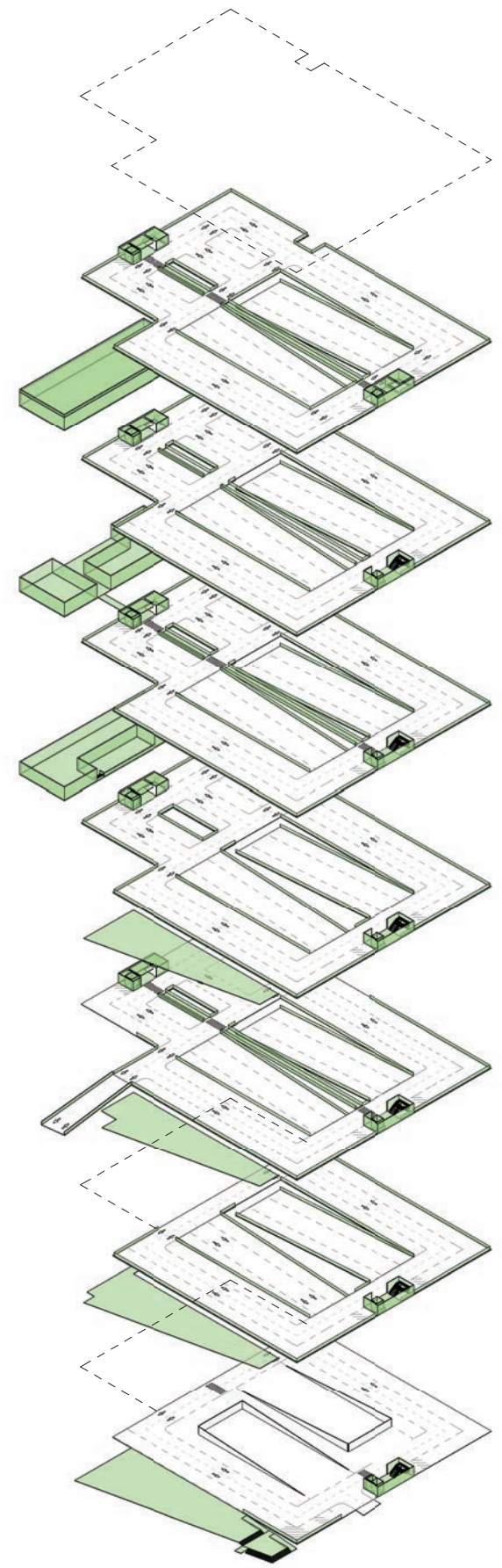

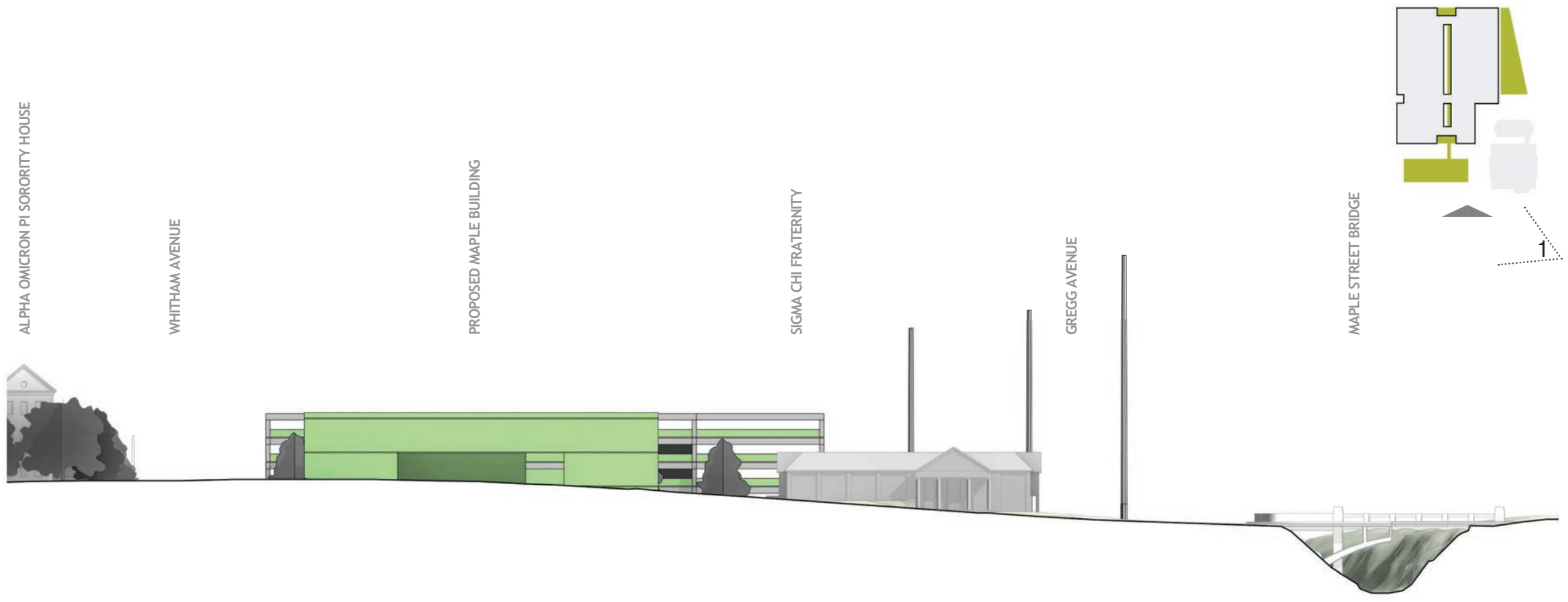

The proposed stand-alone building on Maple aligns its entry porch with the primary axis of Arkansas Avenue. At 2 levels above grade, it begins to mimic the scale and proportion of the Sigma Chi house to the east.

a. MAPLE STREET ELEVATION

1:60



This view encompasses campus entry at Maple Street Bridge facing west. The proposed Delta Gamma Sorority House can be seen on the left with Sigma Chi Fraternity on the right. The parking garage at 7 levels above Douglas still blends well behind Sigma Chi and the proposed Maple building.

1. INTERSECTION OF MAPLE/GREGG

Cut directly through the center of Arkansas Avenue, this section shows the relationship of the garage to the proposed building along Maple. A pedestrian bridge connects to the garage at Level 5, while the lower level steps up to communicate with Level 4.

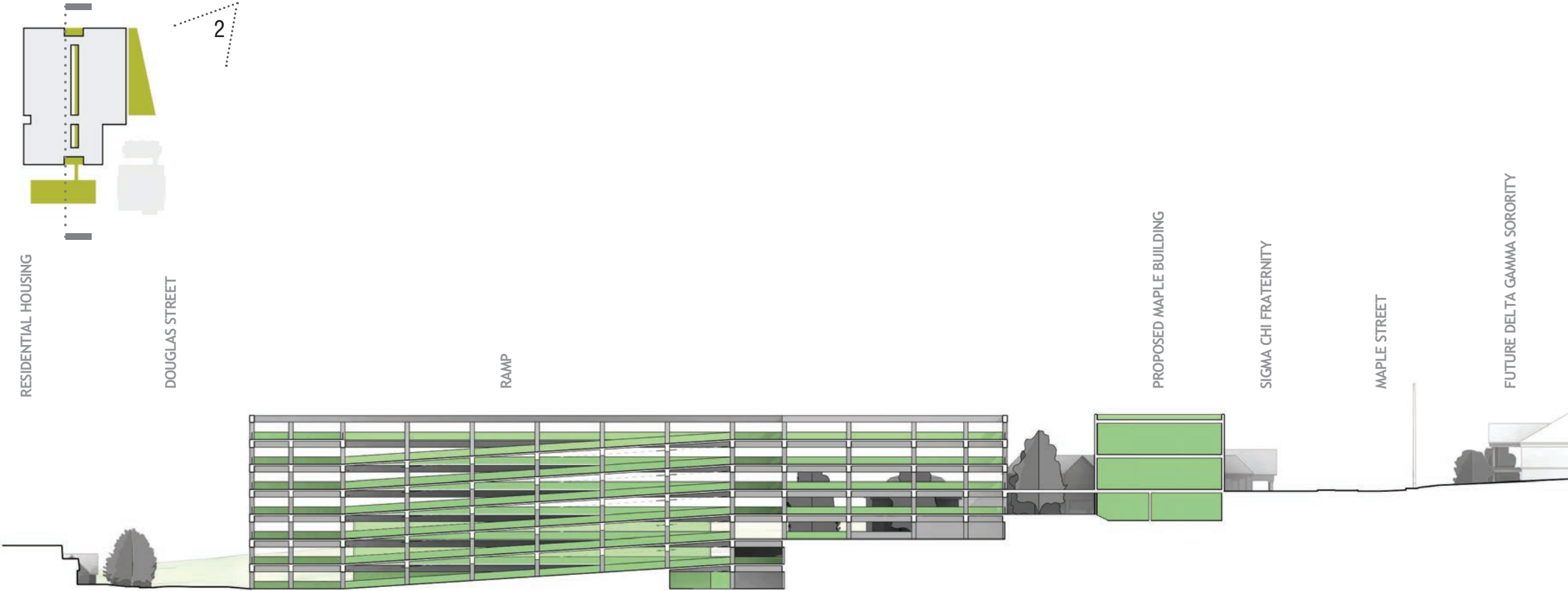

SECTION A

1:60

The view looking south along Gregg Avenue would be the approach coming from Frisco Trail. The garage is pushed back from the edge of the property and a proposed liner building is shown as a transition for trail patrons entering campus from the north.

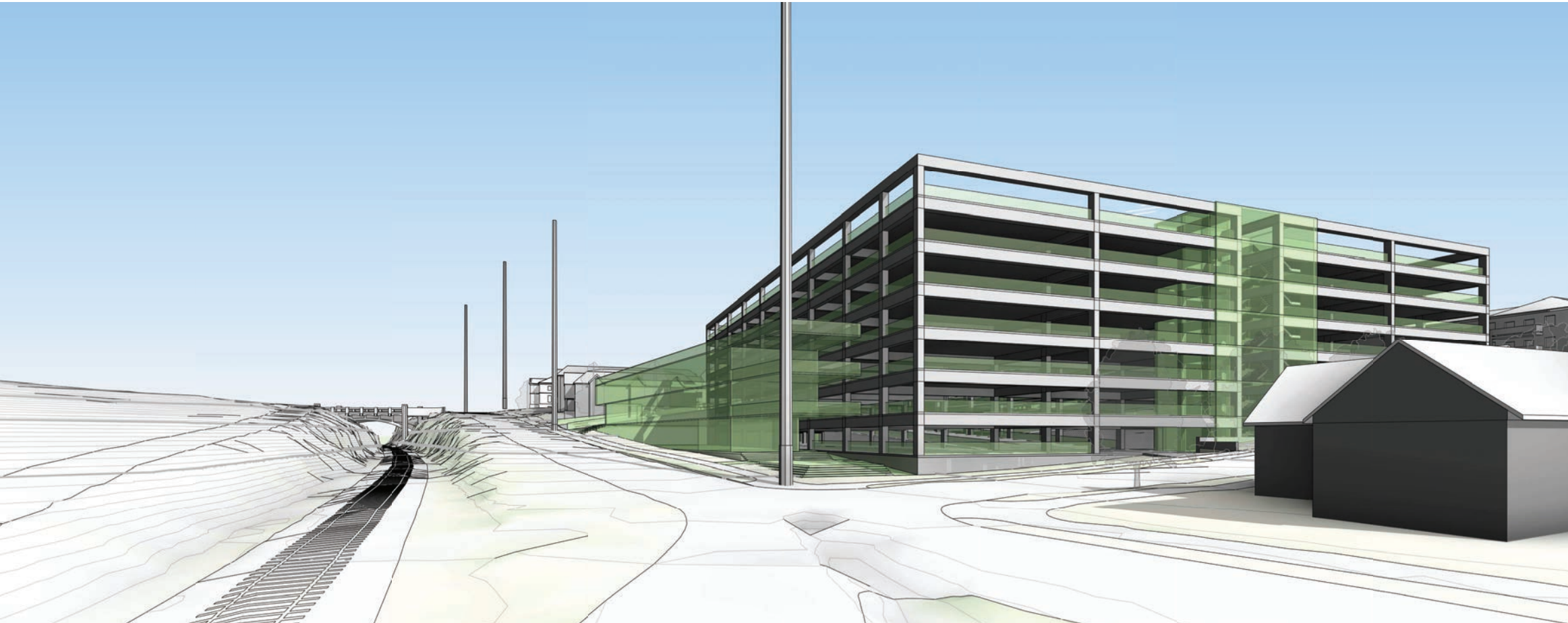

2. INTERSECTION OF GREGG/DOUGLAS

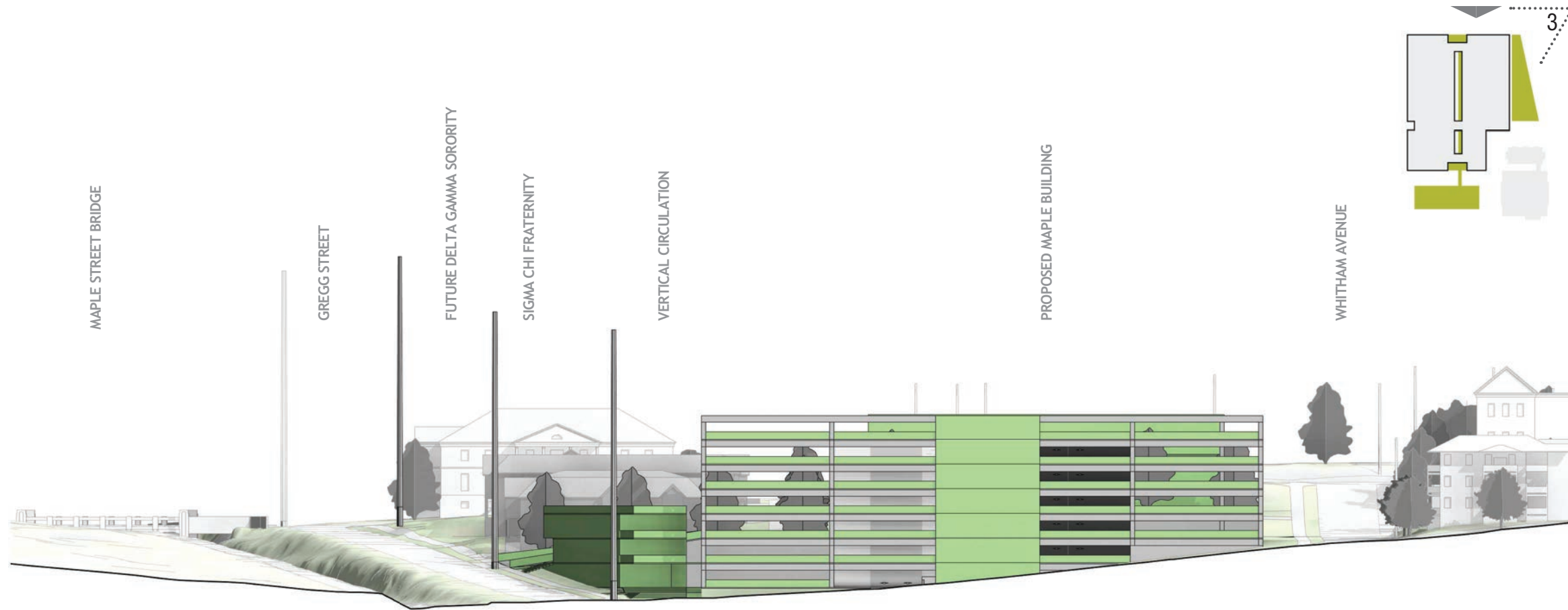

The street elevation at Douglas captures the surrounding Greek buildings beyond. The proposed garage remains below the crown of the roof of most of the surrounding context.

c. DOUGLAS STREET ELEVATION

1:60

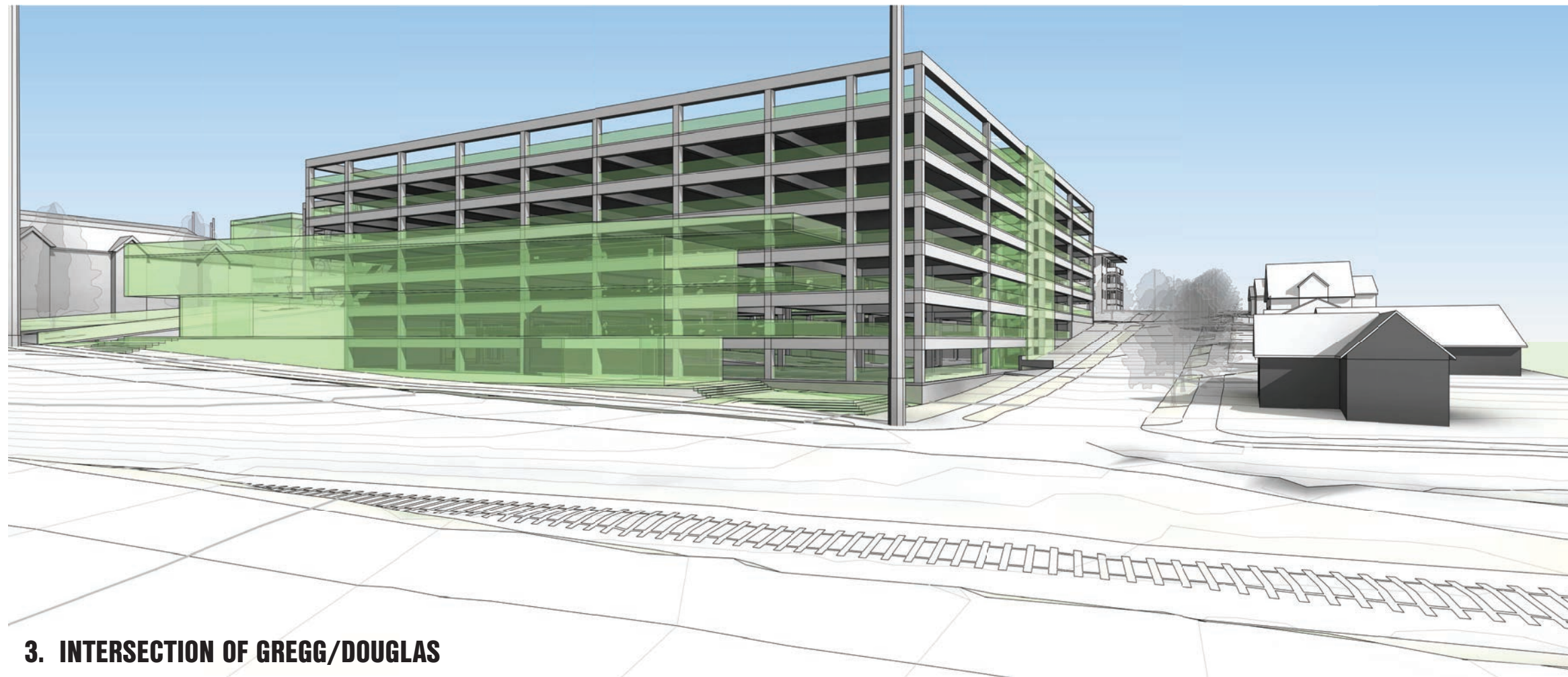

3. INTERSECTION OF GREGG/DOUGLAS

The northeast corner of the garage will appear tallest here due to existing grade. Contextually, the garage is not a good match for the single-family residences along Douglas. Facade screening could be implemented to break up the facade in scale and better relate to the residential housing. Future development along Douglas might consider the scale and proportion of the 3 story multi-family residential seen in the distance on the corner of Whitham and Douglas.

A section cut further east shows the correlation of the proposed garage in relation to the Sigma Chi House. Also shown is the disproportionate relationship between a garage of any substantial height and houses along Douglas.

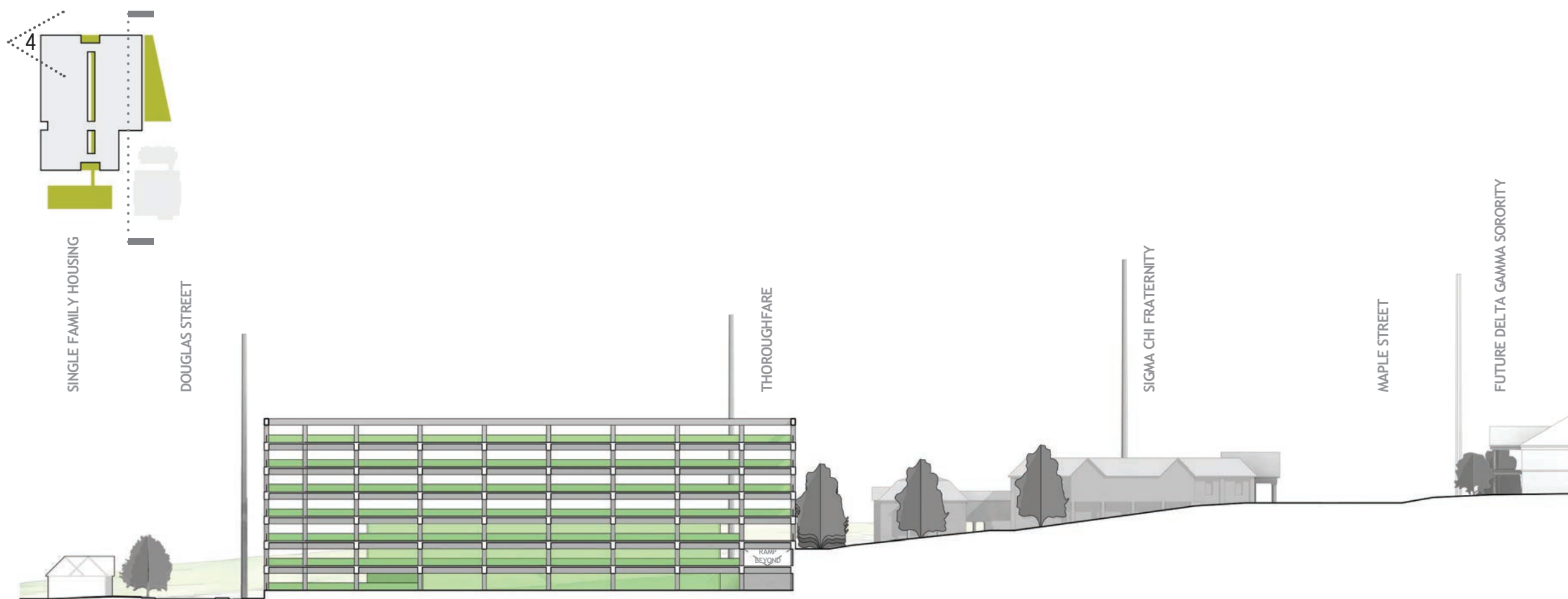

SECTION B

1:60

A view looking east along Douglas begins to show the similarity in scale between the multi-family housing and the parking garage with 2 levels below grade at Whitham.

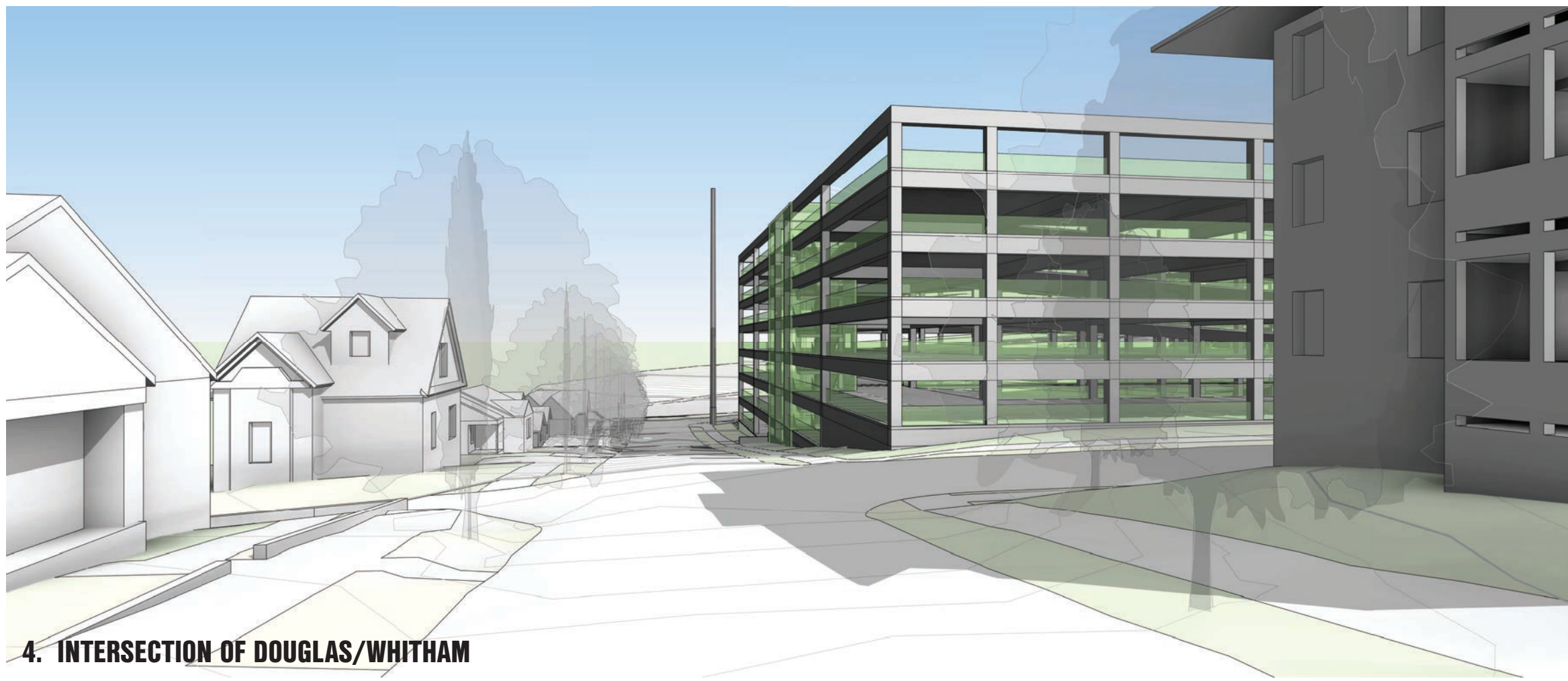

4. INTERSECTION OF DOUGLAS/WHITHAM

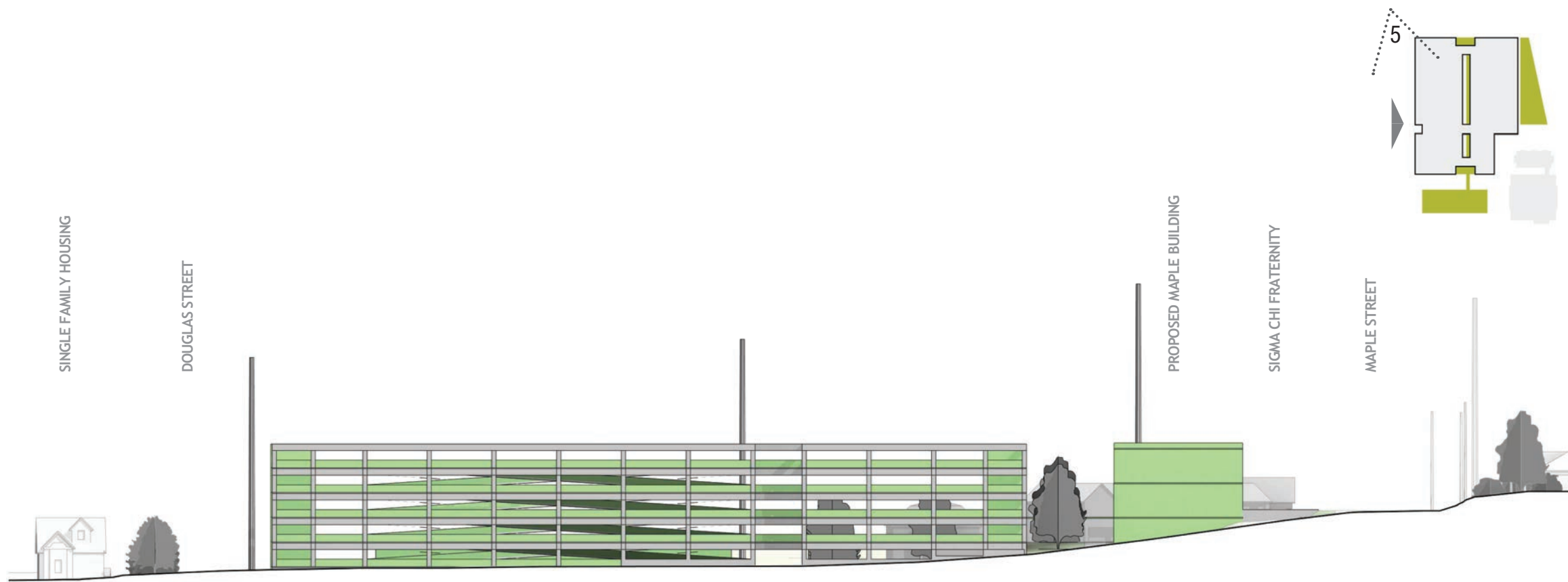

The garage takes advantage of the minimal slopes along Whitham aligning with Level 3 of the garage for a majority of the façade. Just south of the vertical circulation, the existing grade makes a quick transition up to Maple allowing for a building that matches the limits of the garage.

d. WHITHAM AVENUE ELEVATION

1:60

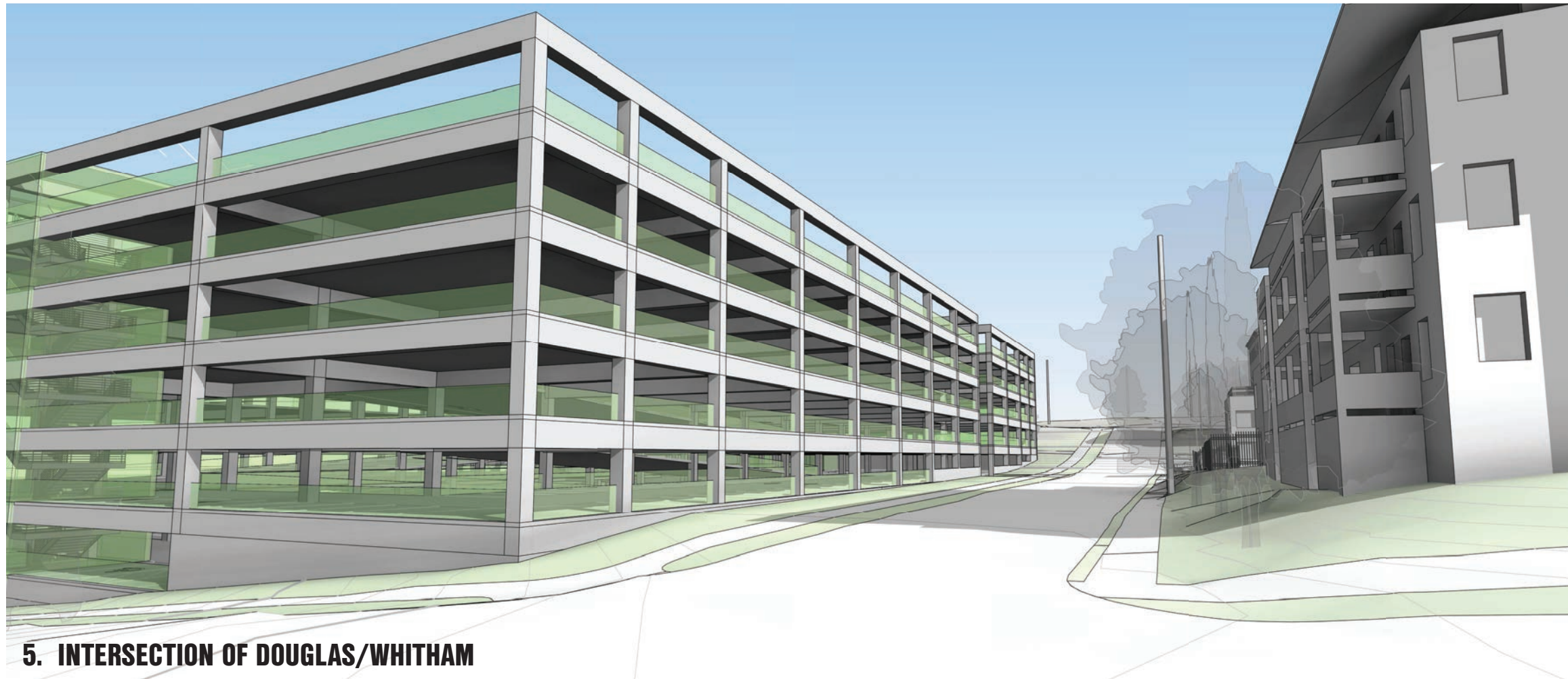

A view looking south along Whitham further enforces the preferred streetscape of two closely proportioned structures on either side of a pedestrian friendly city street.

5. INTERSECTION OF DOUGLAS/WHITHAM

A cross section through the garage shows a larger lightwell with pedestrian bridges at Levels 3, 5, and 7. The height of the garage is diminished along Gregg Avenue by pulling the structure back and proposing a liner building of smaller stature.

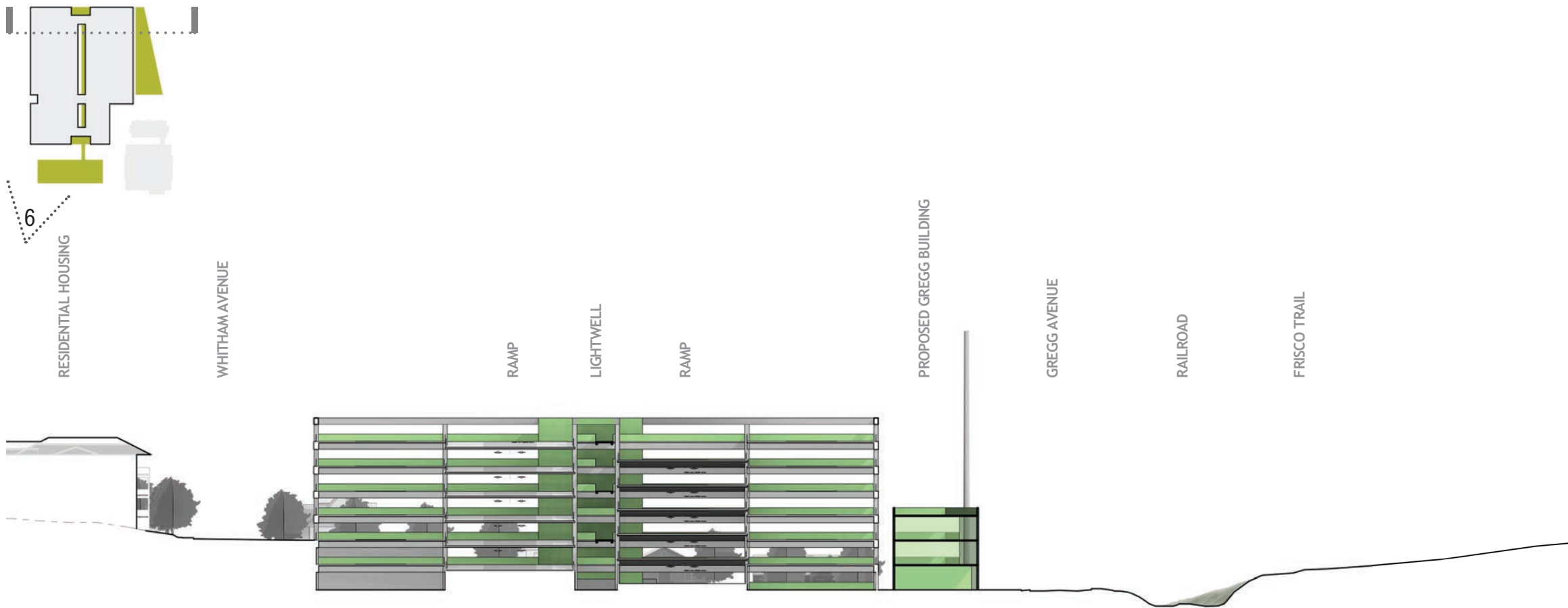

SECTION C

1:60

The height of the proposed building along Maple is a direct nod to the scale and proportion of the neighboring Alpha Omicron Pi House. As the garage makes its transition into the hillside, the relationship to the multi-family housing can be seen in the distance.

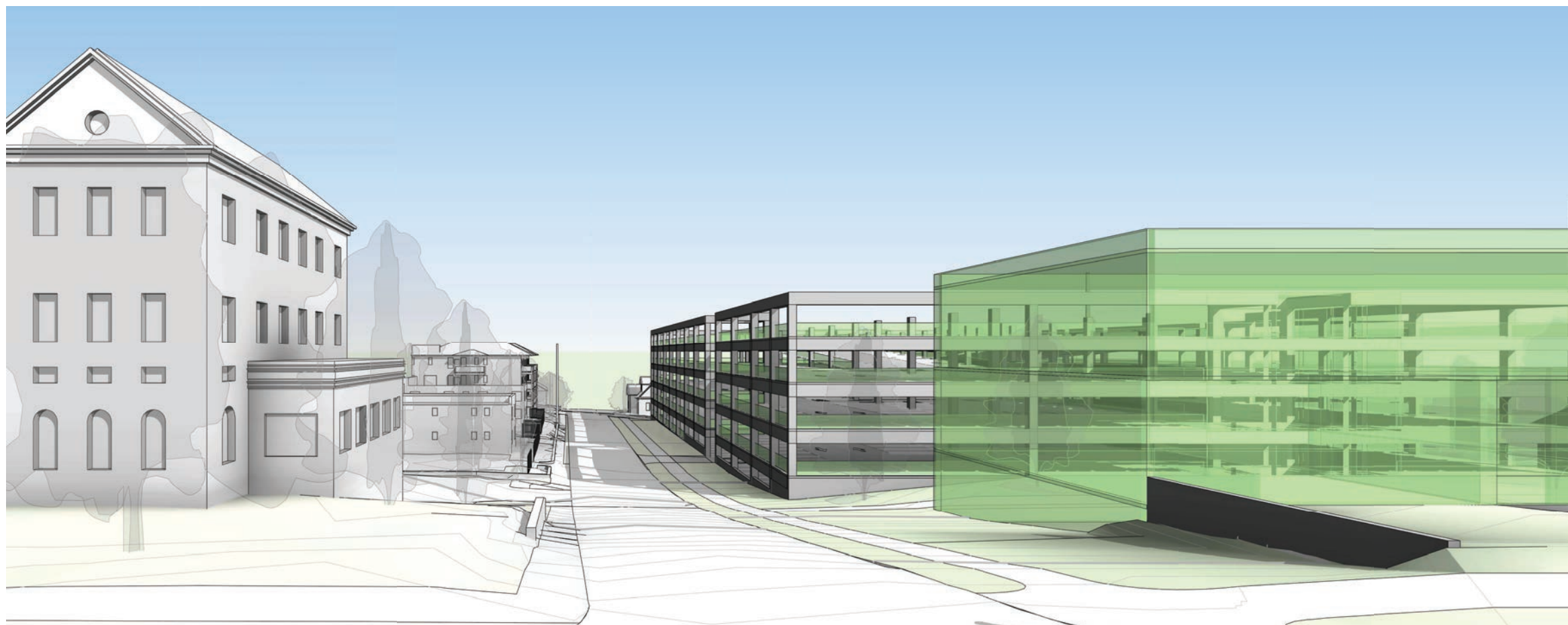

6. INTERSECTION OF WHITHAM/MAPLE

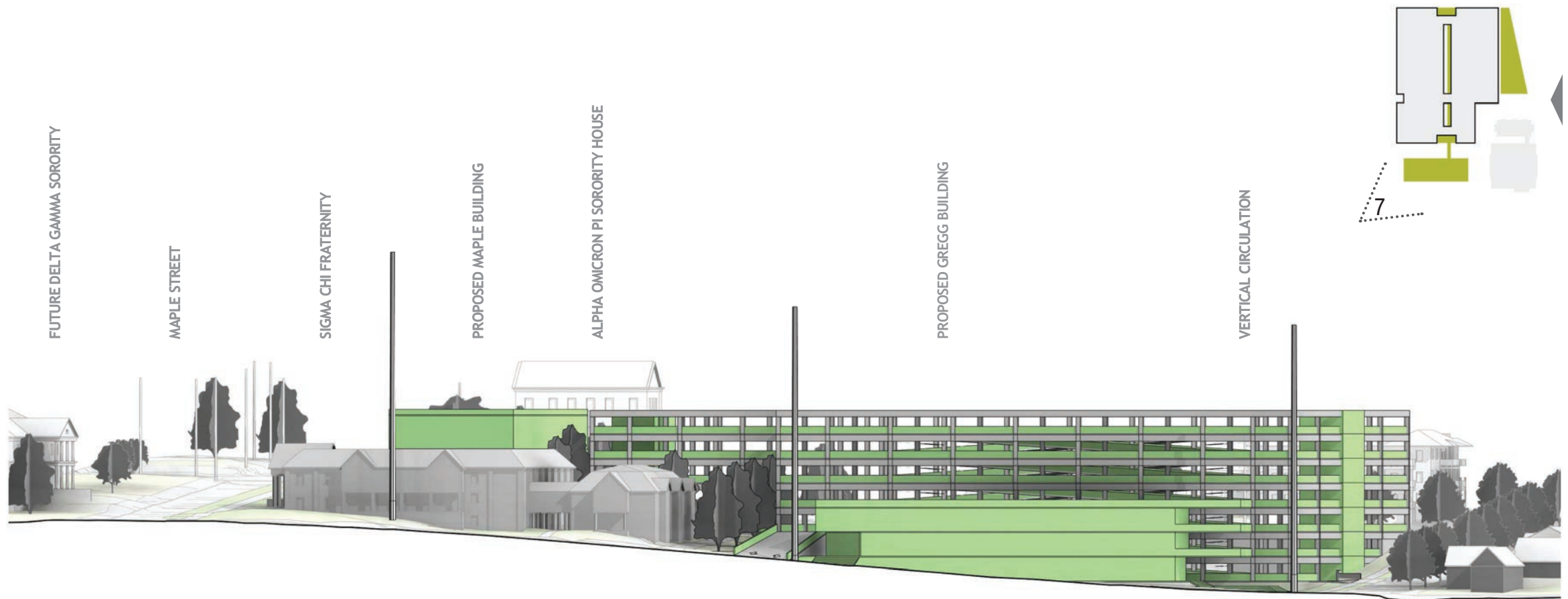

A street elevation along Gregg Avenue shows a steady drop in grade from south to north. While this does allow the garage to sit much lower in relation to Maple Street, it could make entry/exit along Gregg difficult. By pulling the garage back from the edge of Gregg, the transition is easily handled by a longer drive leading to the entry/exit point.

b. GREGG AVENUE ELEVATION

1:60

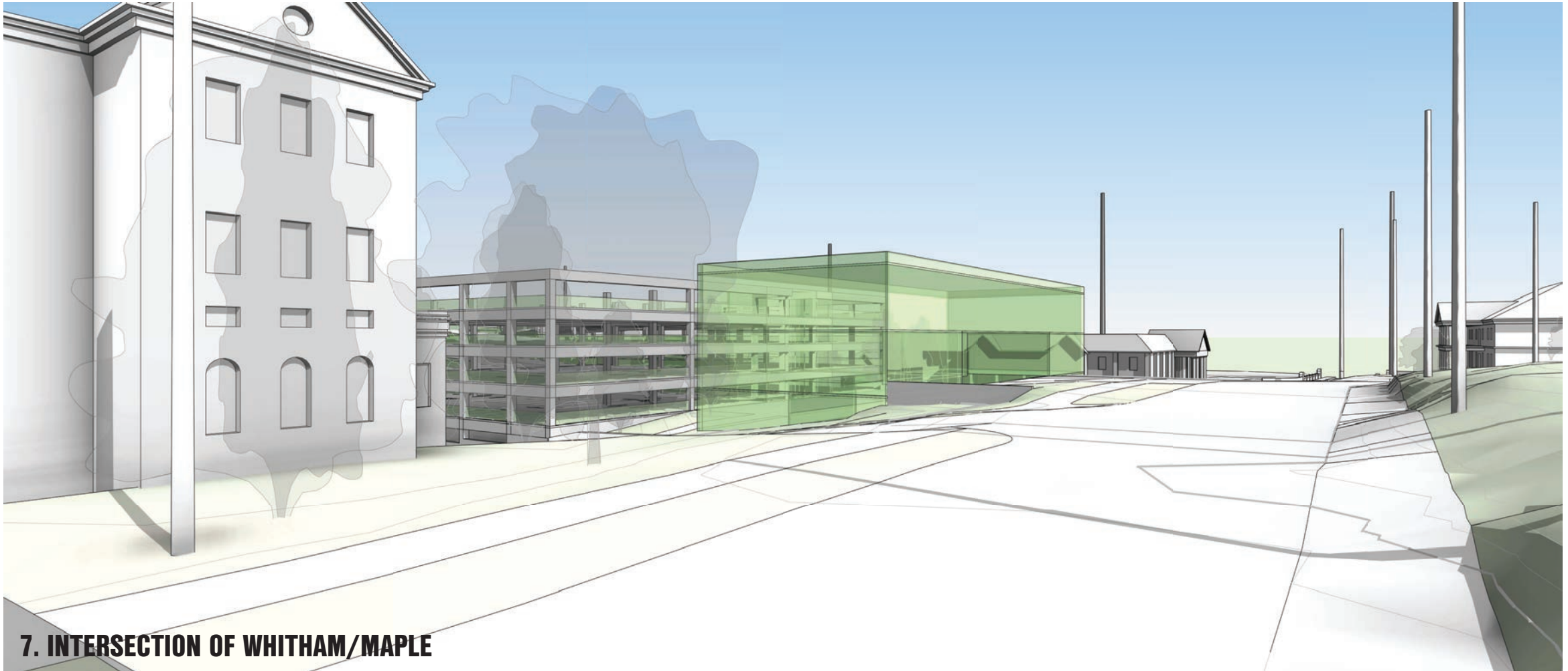

7. INTERSECTION OF WHITHAM/MAPLE

The proportion and scale of any proposed structure along Maple should be a careful balance between Alpha Omicron Pi to the west and Sigma Chi to the east. Also of note is the proposed Delta Gamma house on the south side of Maple.

OPTION C.1

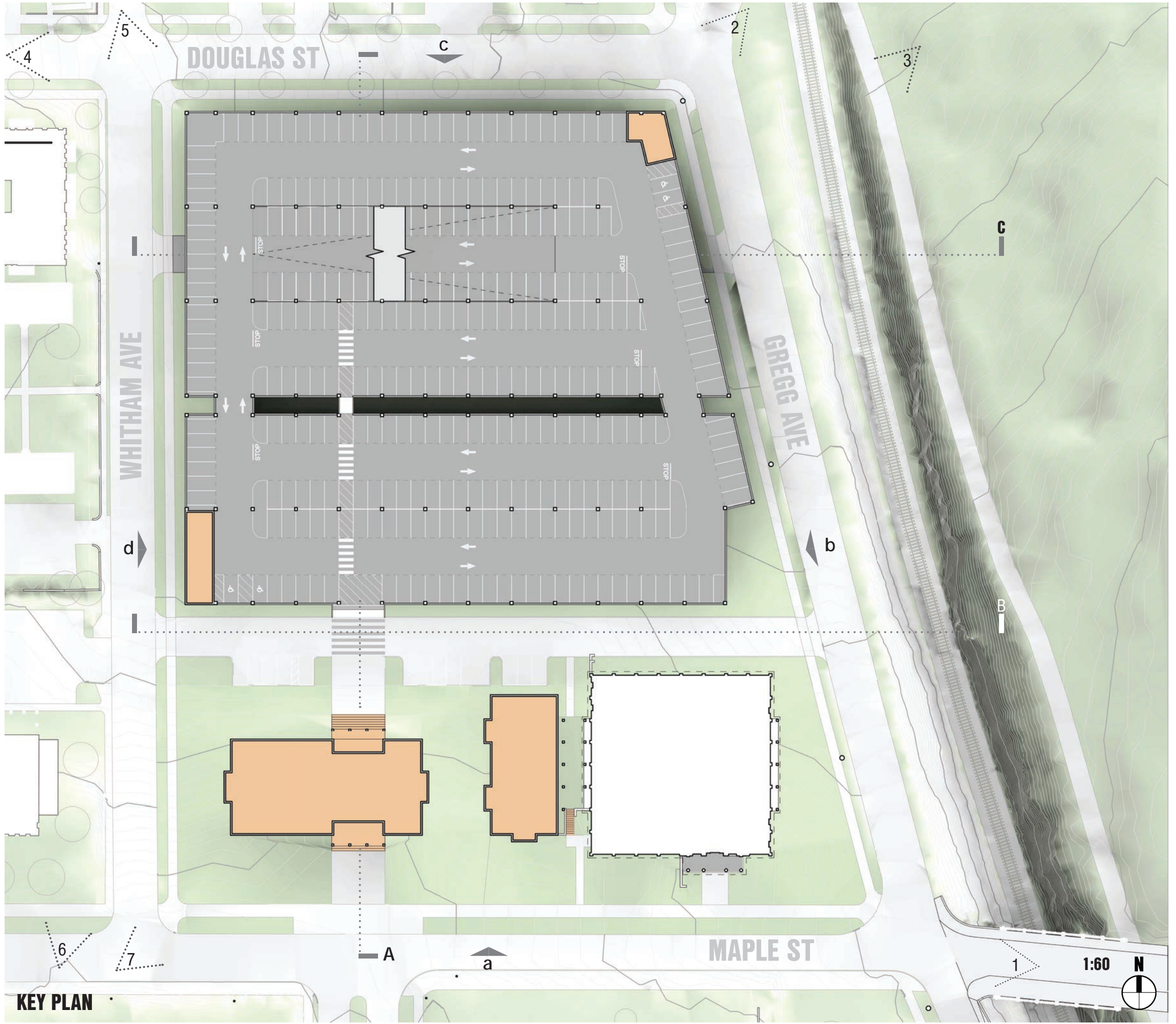
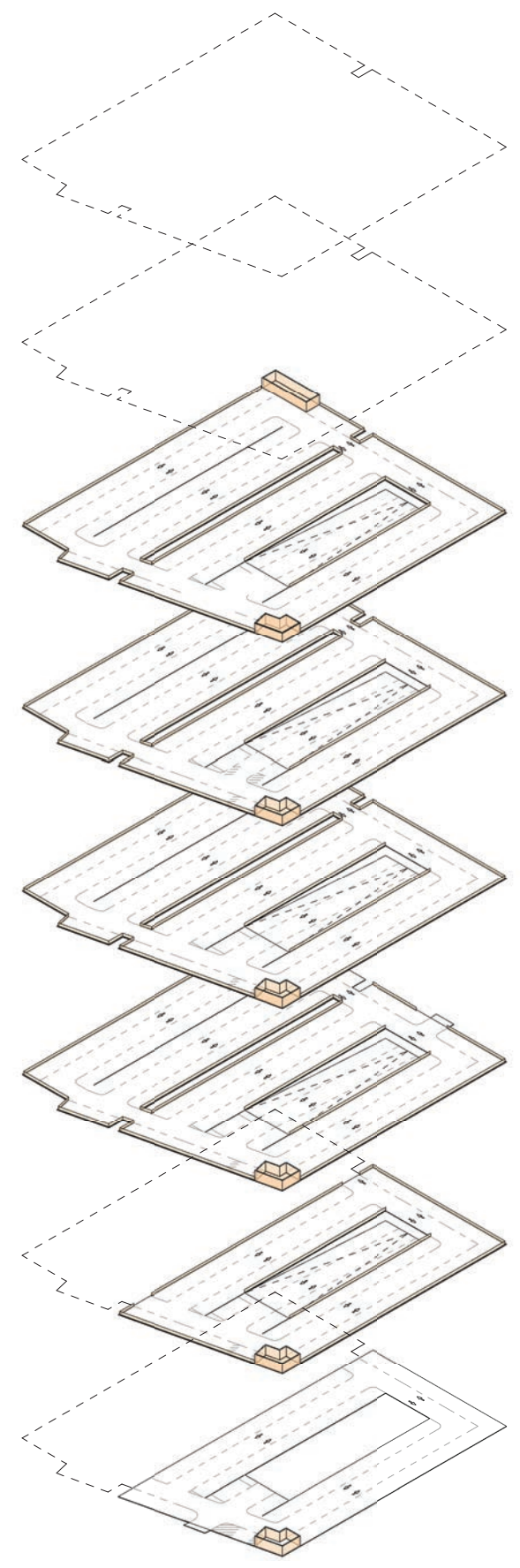

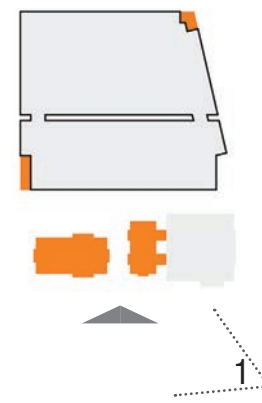
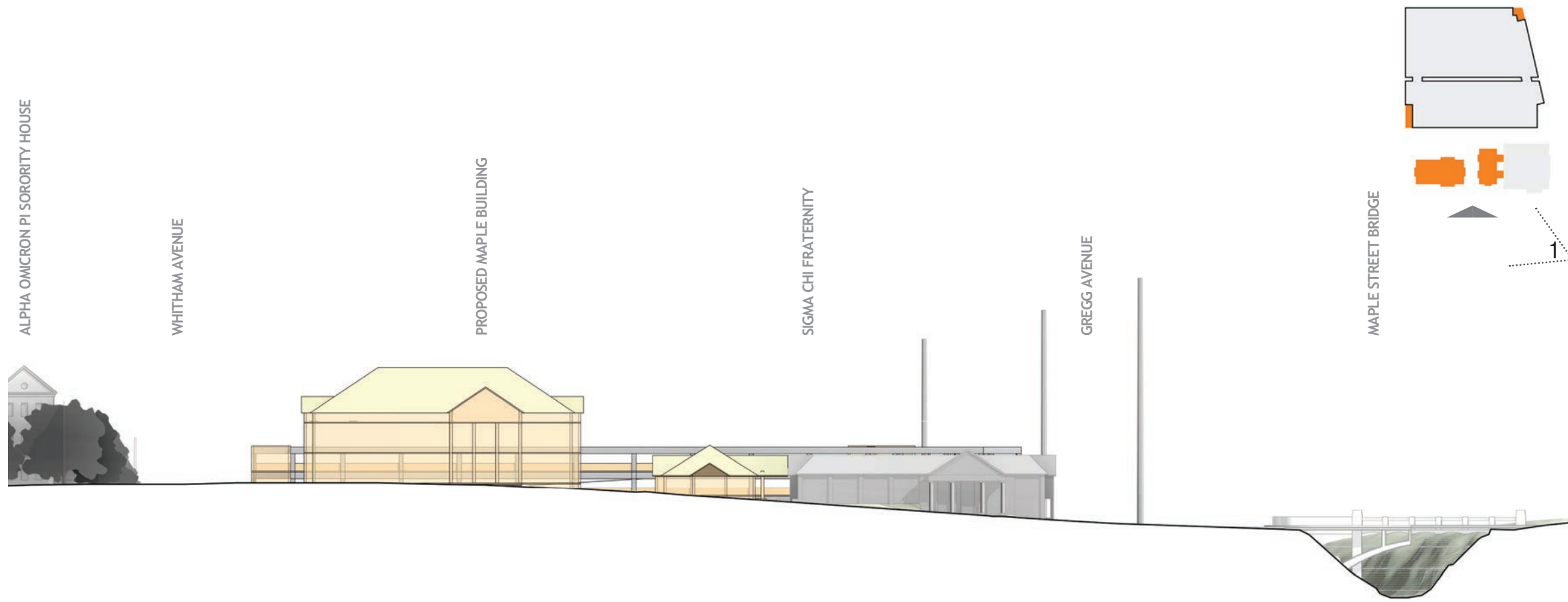

The proposed building on Maple aligns its entry porch with the primary axis of Arkansas Avenue. At roughly 2 ½ levels above grade, it begins to mimic the scale and proportion of other structures along Sorority Row. The proposed relocation of the Sigma Chi Annex can also be seen as a unassuming addition to the existing house.

a. MAPLE STREET ELEVATION

1:60



This view encompasses campus entry at Maple Street Bridge facing west. The proposed Delta Gamma Sorority House can be seen on the left with Sigma Chi Fraternity on the right. The parking garage at 6 levels above Douglas is tucked neatly behind Sigma Chi and the proposed Maple building.

1. INTERSECTION OF MAPLE/GREGG

Cut directly through the center of Arkansas Avenue, this section shows the relationship of the garage to the proposed building that fronts Maple. An alleyway separates both the proposed building and Sigma Chi from the garage with ample green space and surface parking between the two distinct uses.

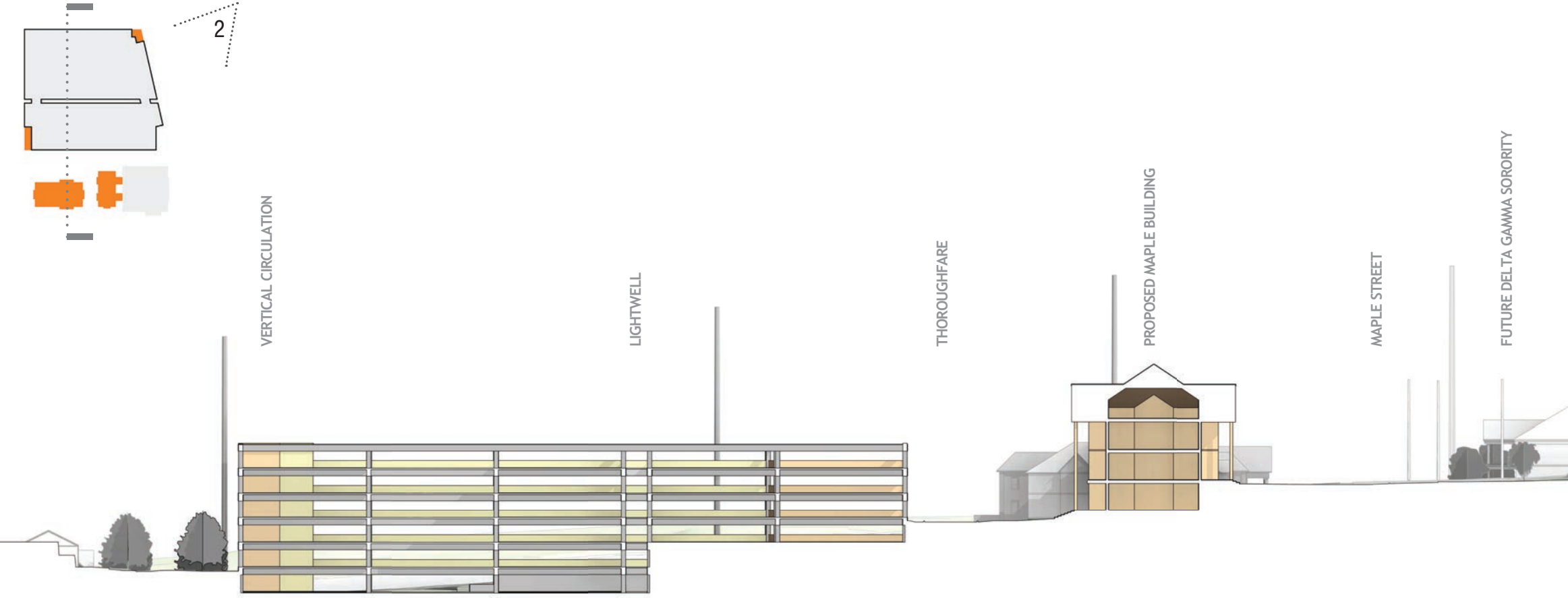

SECTION A

1:60

The view looking south along Gregg Avenue would be the approach coming from Frisco Trail. Vertical circulation at this corner of the garage would be advantageous for trail patrons who are making their way onto campus.

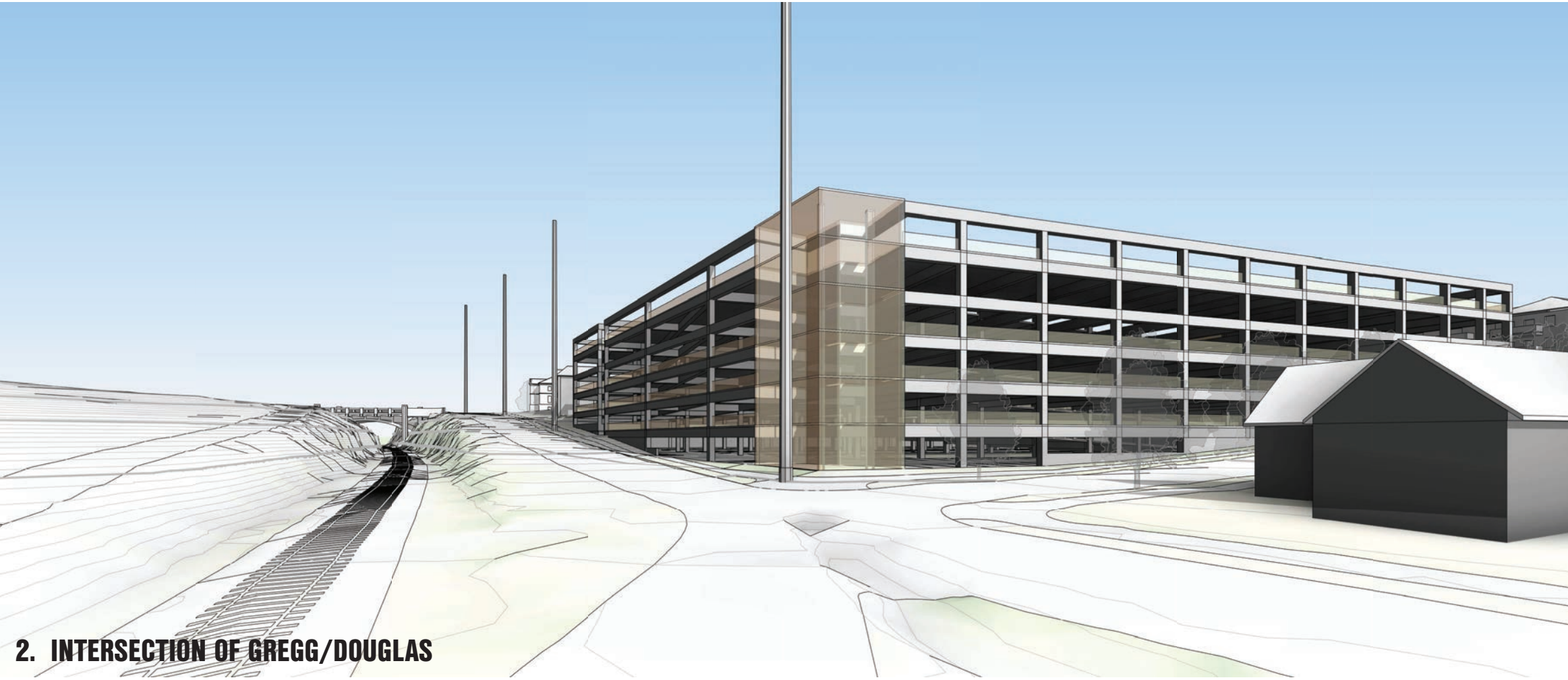

2. INTERSECTION OF GREGG/DOUGLAS



The street elevation at Douglas captures the surrounding Greek buildings beyond. The proposed garage remains below the crown of the roof of all surrounding context.

c. DOUGLAS STREET ELEVATION

1:60

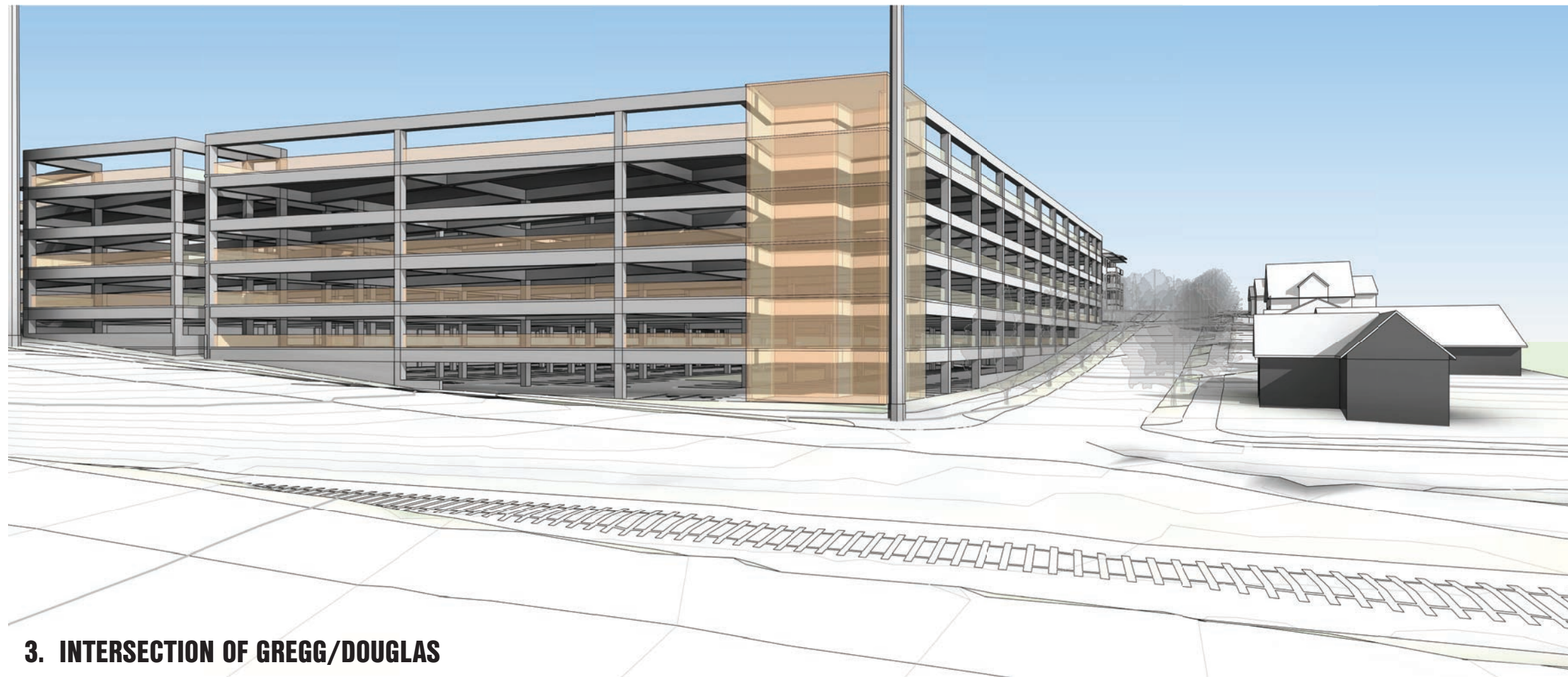

The northeast corner of the garage will appear tallest here due to existing grade. Contextually, the garage is not a good match for the single-family residences along Douglas. Facade screening could be implemented to break up the facade in scale and better relate to the residential housing. Future development along Douglas might consider the scale and proportion of the 3 story multi-family residential seen in the distance on the corner of Whitham and Douglas.

3. INTERSECTION OF GREGG/DOUGLAS

A section cut through the alleyway shows the moderate transition from Whitham to Gregg. The vehicular traffic that moves through this alley is for Sigma Chi and the proposed Maple building only. Parking traffic remains separated from the southern half of the project limits.

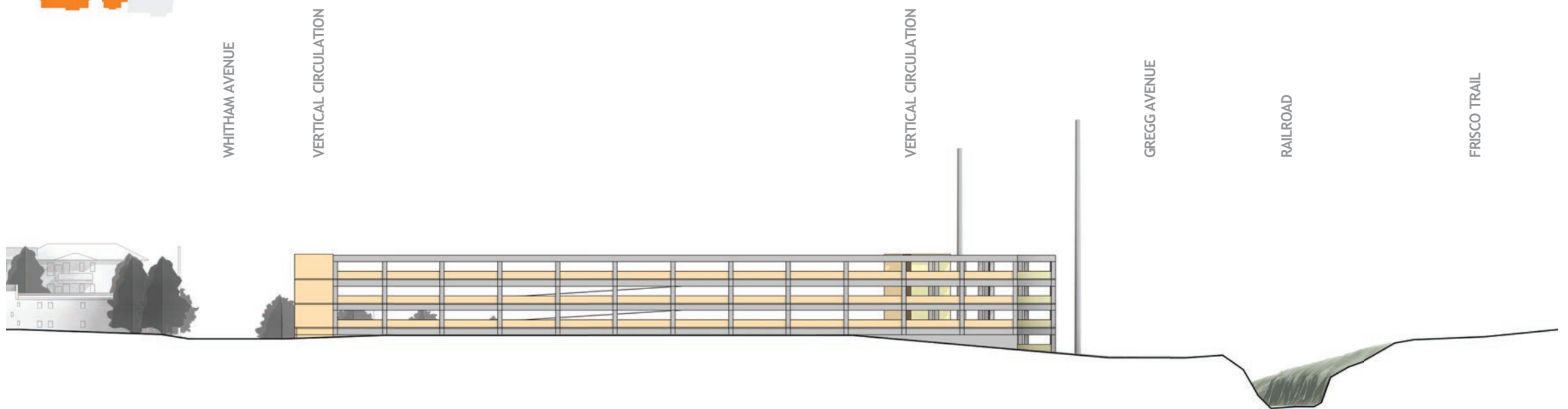
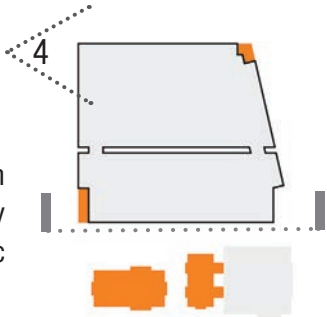

SECTION B

1:60

A view looking east along Douglas begins to show the similarity in scale between the multi-family housing and the parking garage with 2 levels below grade at Whitham.

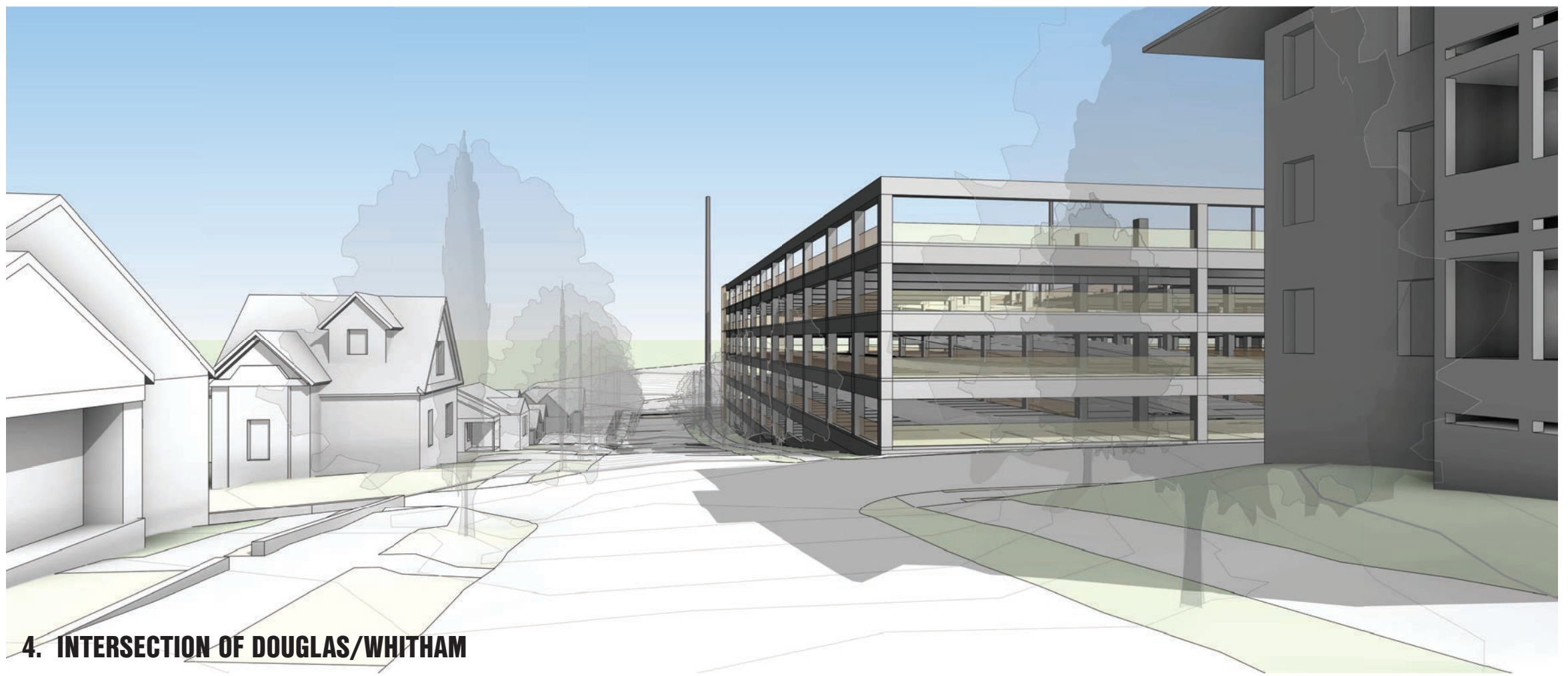

4. INTERSECTION OF DOUGLAS/WHITHAM

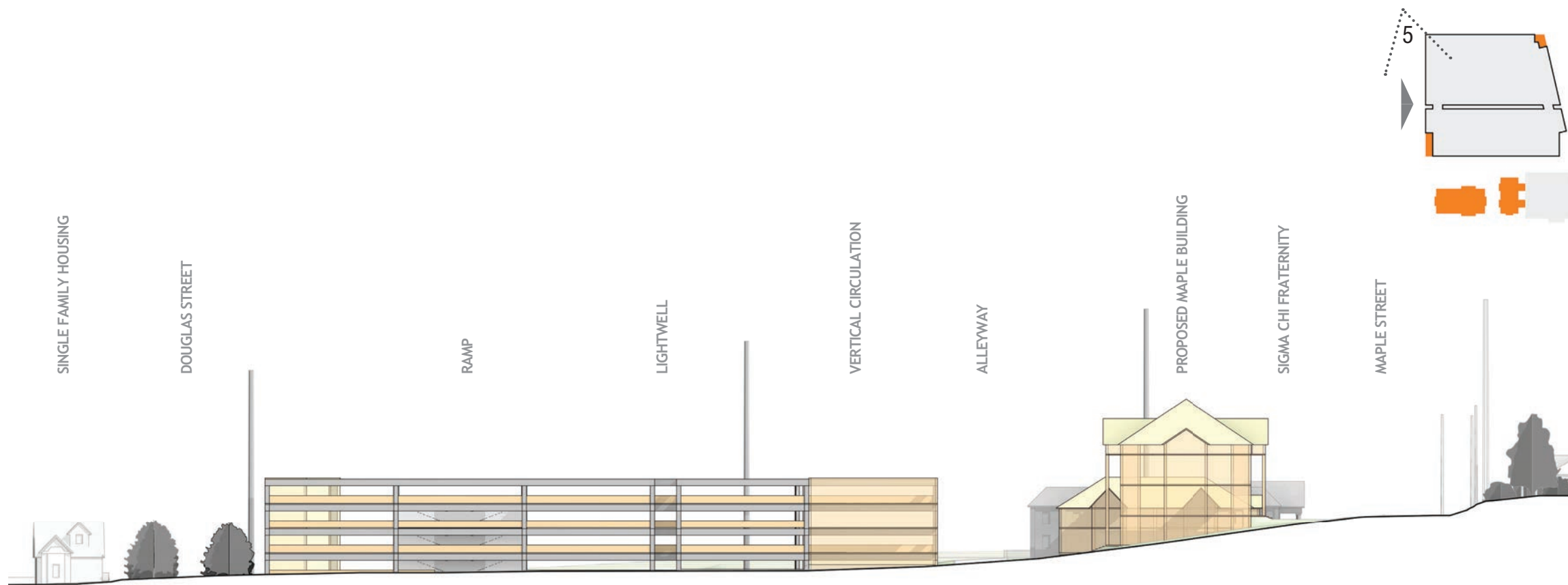

The garage takes advantage of the minimal slopes along Whitham aligning with Level 3 of the garage for a majority of the façade. Just south of the vertical circulation, the existing grade makes a quick transition up to Maple allowing for a building that sits well above the limits of the garage.

d. WHITHAM AVENUE ELEVATION

1:60

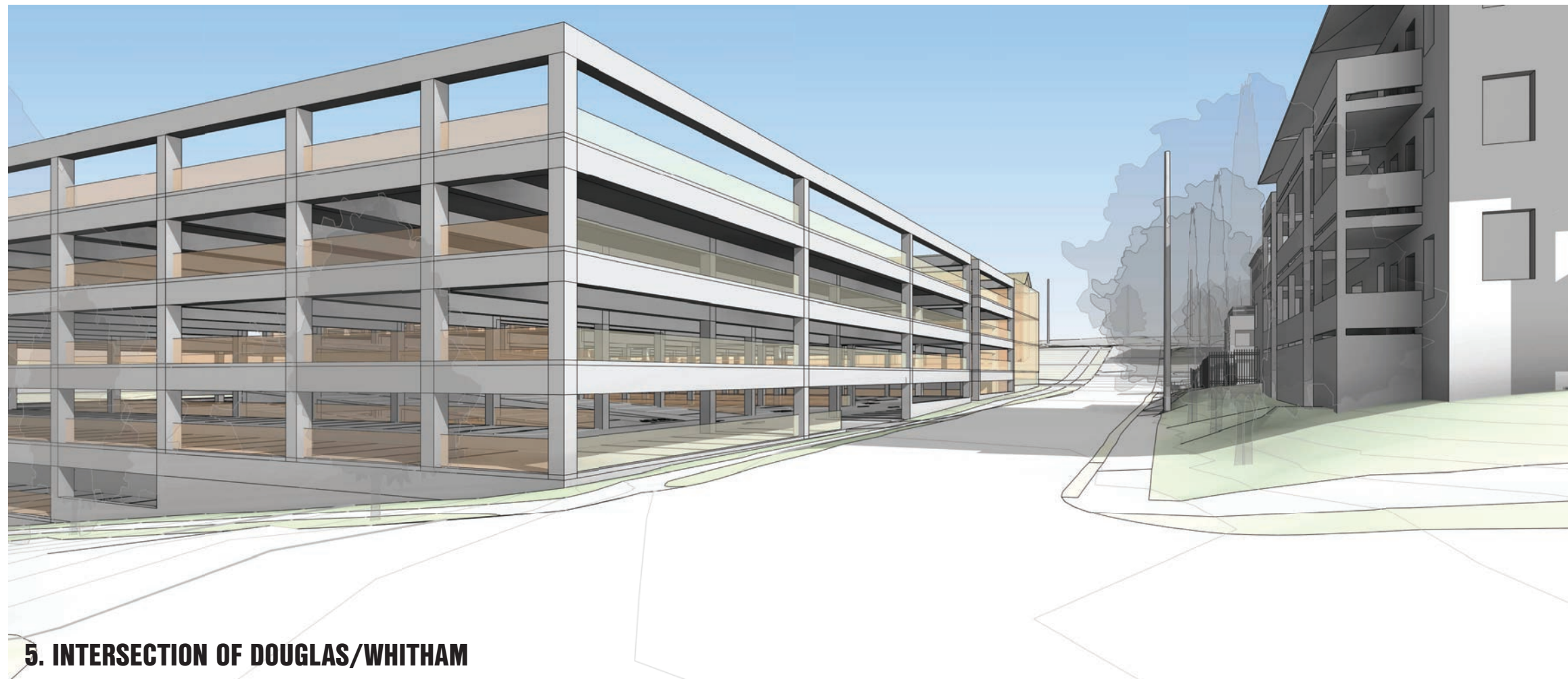

A view looking south along Whitham further enforces the preferred streetscape of two closely proportioned structures on either side of a pedestrian friendly city street.

5. INTERSECTION OF DOUGLAS/WHITHAM

A cross section through the parking ramps shows a Level 3 entry point off of Whitham taking traffic immediately up to Level 4 and the remaining upper levels of the garage

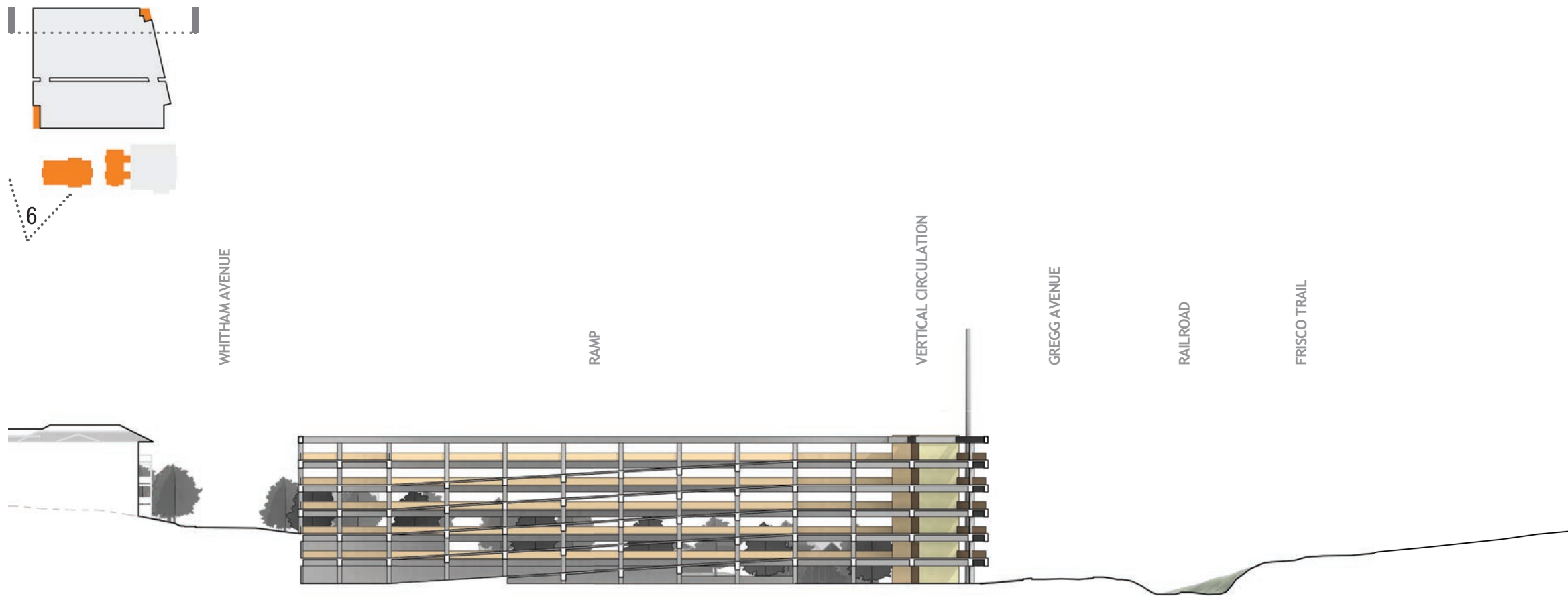

SECTION C

1:60

The height of the proposed building along Maple is a direct nod to the scale and proportion of the neighboring Alpha Omicron Pi House. As the garage makes its transition into the hillside, the relationship to the multi-family housing can be seen in the distance.

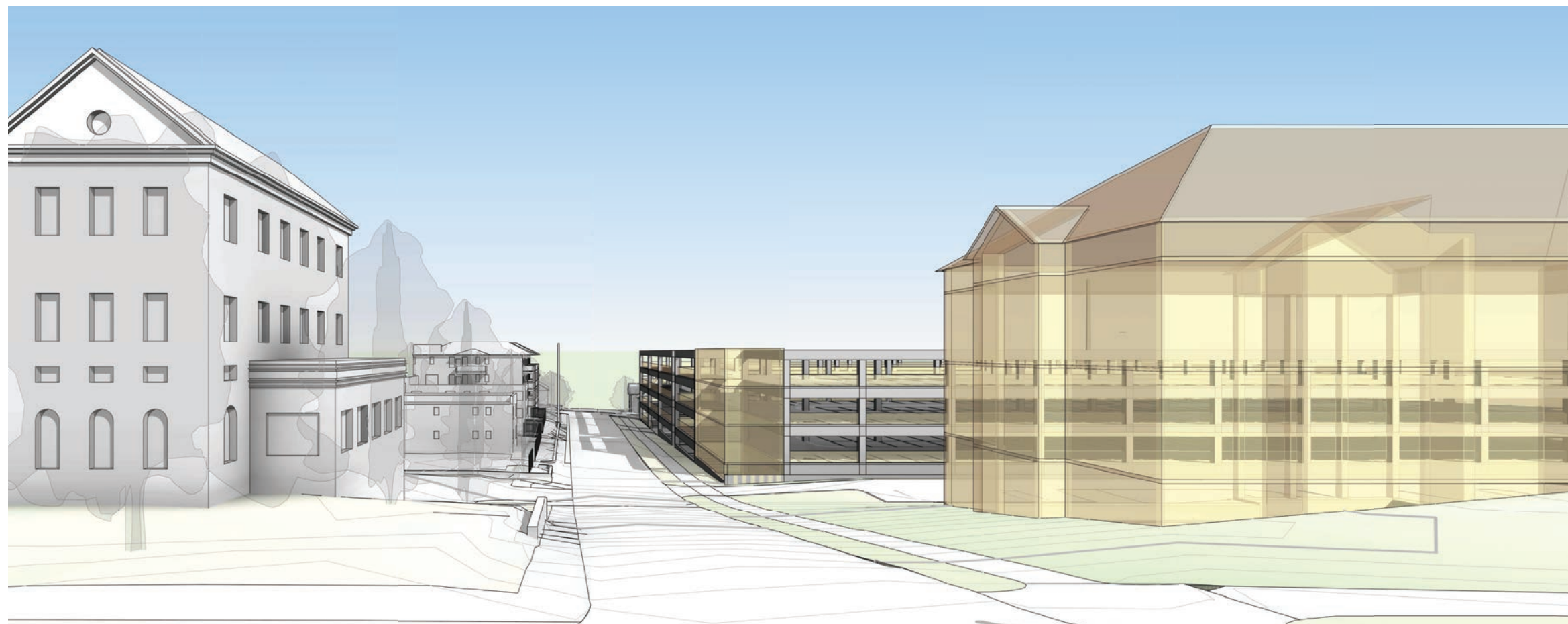

6. INTERSECTION OF WHITHAM/MAPLE

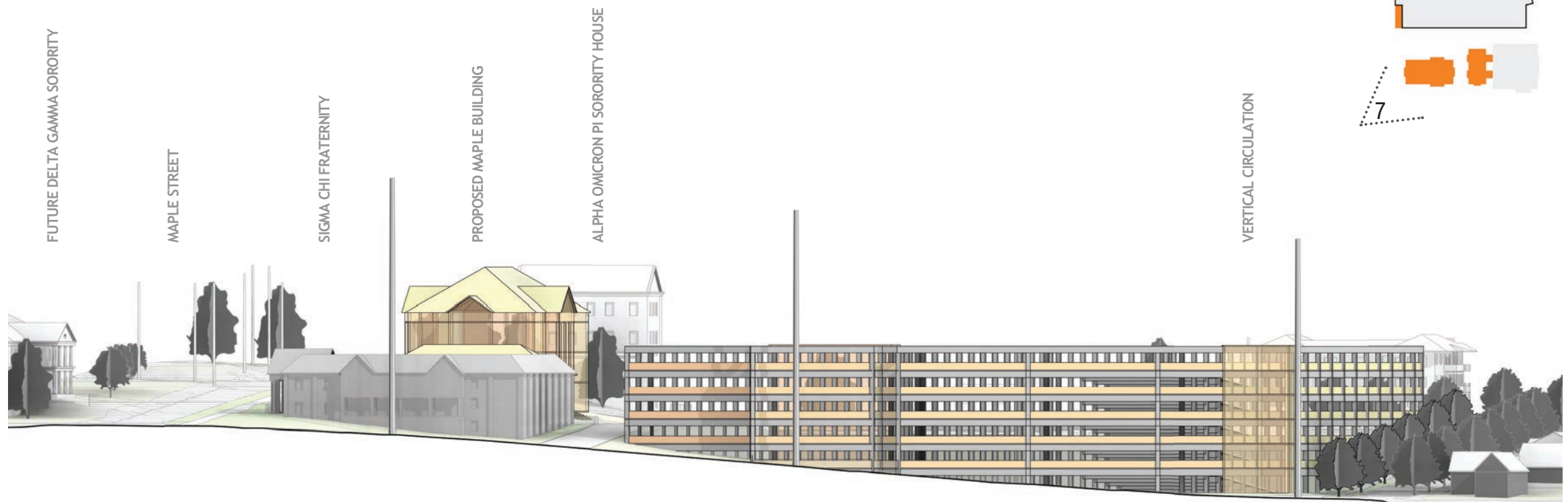

A street elevation along Gregg Avenue shows a steady drop in grade from south to north. While this does allow the garage to sit much lower in relation to Maple Street, it could make entry/exit along Gregg difficult without slight modifications to the street.

b. GREGG AVENUE ELEVATION

1:60



The proportion and scale of any proposed structure along Maple should be a careful balance between Alpha Omicron Pi to the west and Sigma Chi to the east. Also of note is the proposed Delta Gamma house on the south side of Maple.

7. INTERSECTION OF WHITHAM/MAPLE

TRAFFIC IMPACT ASSESSMENT

Shown mapped is the traffic variation of commute flows between:

1. Existing Scenario
2. Existing Scenario with Gregg Extension from Douglas St. to Cleveland St. and road diet on Maple St.

The new Gregg Avenue extension will create a new route out of downtown, reducing traffic on Maple Street on and near campus. In turn, there will be increased vehicle traffic on the local streets surrounding the proposed parking garage site.

*represents an estimation of one-way commute flow- 60% of which occurs during peak traffic hours

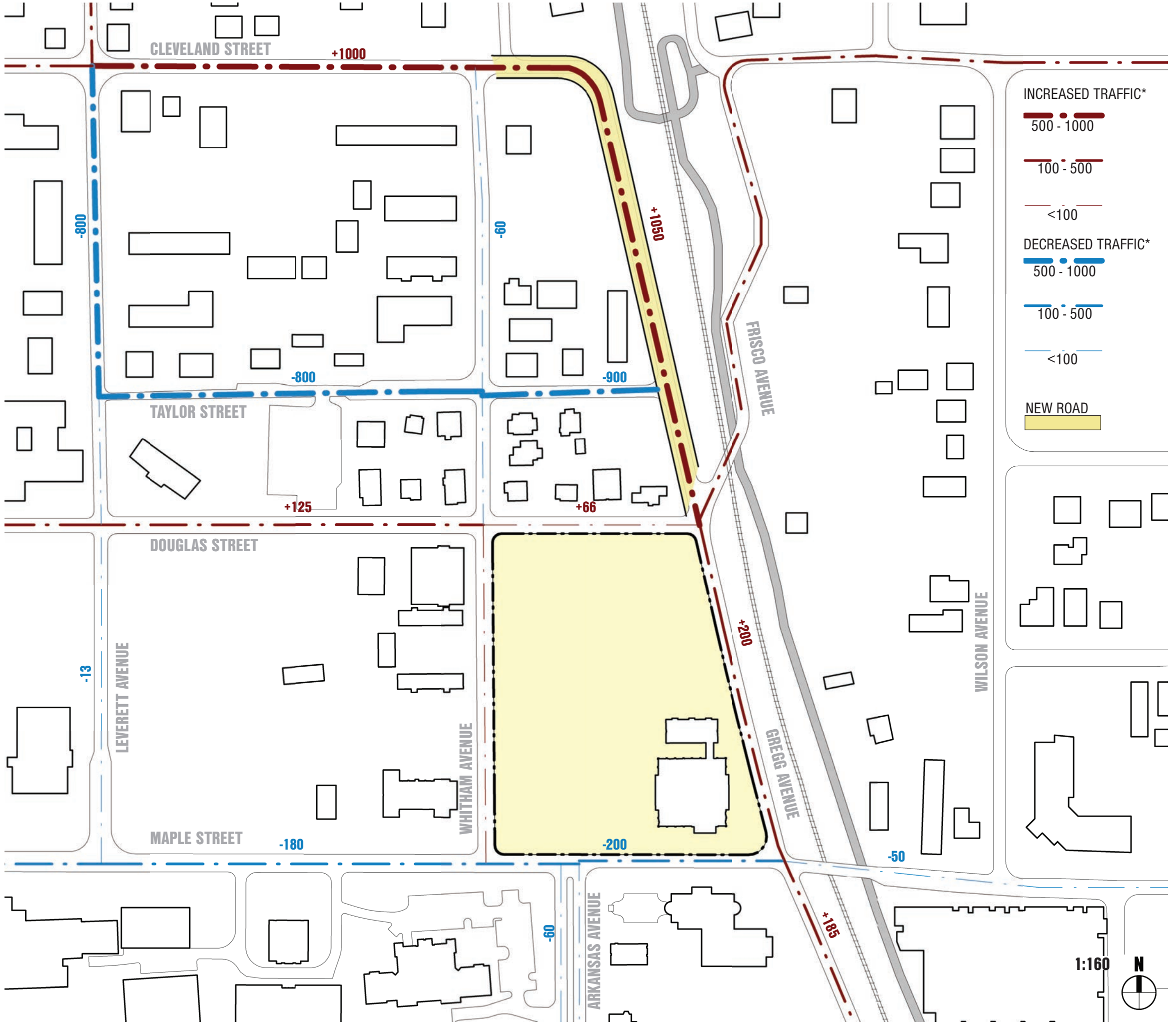

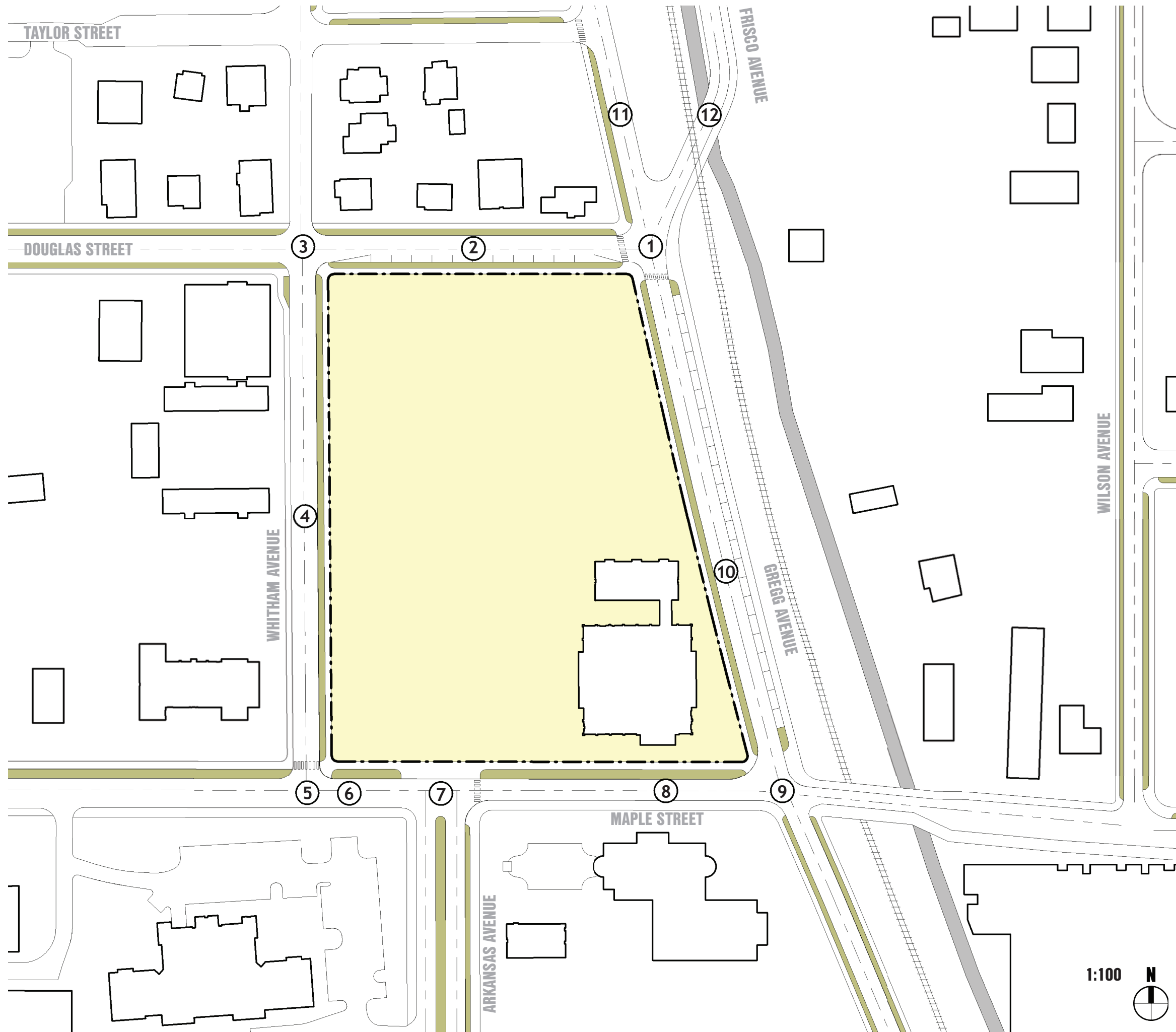



PROPOSED STREETScape IMPROVEMENTS

1. At the intersection of Douglas, Gregg, and Frisco new curb lines clean up their geometry. N/S and E/W crosswalks are added across Douglas and Gregg respectively.
2. Master plan redevelopment is now continuous along Douglas Street. Along the north sidewalks are rebuilt and new trees are added. Along the south parallel parking is provided in addition to new curbs and sidewalks.
3. The intersection of Douglas to Whitham becomes a four way stop.
4. Whitham gains sidewalks on both sides and are improved and extended along the east for garage accessibility.
5. The Whitham and Maple intersection gains an E/W crosswalk continuing off the Maple sidewalk.
6. Maple stays as two way traffic but in the future will undergo a road diet and have a bidirectional bike lane on the south side.
7. The intersection of Maple and Arkansas will be the major pedestrian connection from the garage to the NE corner of campus. A N/S crosswalk will align with the east sidewalk along Arkansas Avenue.
8. Maple, east of Arkansas Avenue, will have a new sorority house on the South and two way traffic of two 10' lanes with sidewalks on both sides.
9. The intersection of Gregg and Maple will likely require a traffic signal due to the increase in volume.
10. Between Maple and Douglas, Gregg Street is to have a 22' wide two land road with parking on the east near the railroad tracks. This will require extending the city's right of way.
11. Gregg Avenue will be extended north of Douglas with a 22' wide two land road but no parking. Green space and a sidewalk will be added to the west.
12. Frisco will have a continuation of the east sidewalk continuing from S. Gregg Avenue.

1:100 N



COMPARABLE PROJECT DATA

PROJECT DESCRIPTION	YEAR	# OF SPACES	CONSTRUCTION COST	PROJECT COST
 <p>1. HARMON AVENUE PARKING GARAGE 9 FLOORS FULL EXCAVATION</p>	2005	2,149	\$26,388,732 <ul style="list-style-type: none"> • Deck \$22,736,535 • Liner Building \$2,279,629 • Site Work \$1,372,568 	\$29,900,000
 <p>2. GARLAND AVENUE PARKING GARAGE 6 FLOORS FULL EXCAVATION</p>	2010	1,506	\$22,689,514 <ul style="list-style-type: none"> • Deck • Liner Building (cost not provided) 	\$25,963,000 (deck only)
 <p>3. SPRING STREET MUNICIPAL PARKING DECK 4 FLOORS FULL EXCAVATION</p>	2015	236	\$10,522,106 <ul style="list-style-type: none"> • Deck \$6,815,573 • Liner Building \$3,706,533 	\$12,336,023

COST ESTIMATES

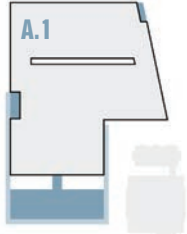
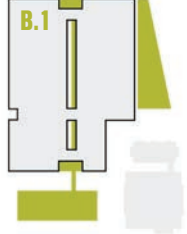
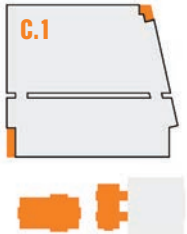
PROJECT DESCRIPTION	YEAR	# OF SPACES	COST PER SPACE	CONST. COST	SOFT COST FACTOR	PROJECT COST
 <p>OPTION A.1 6 FLOORS FULL EXCAVATION</p>	2017	1,522	\$22,000 ¹	\$33,484,000	15% (+5,022,600)	\$38,506,600
 <p>OPTION B.1 7 FLOORS PARTIAL EXCAVATION</p>	2017	1,412	\$20,900 ²	\$29,510,800	15% (+4,426,620)	\$33,937,420
 <p>OPTION C.1 6 FLOORS PARTIAL EXCAVATION</p>	2017	1,564	\$20,900 ²	\$32,687,600	15% (+4,903,140)	\$37,590,740

ANALYSIS

COST PER SPACE	SOFT COST FACTOR (%)	ESCALATION FACTOR (% over 12 months)
$\frac{\text{deck construction cost}}{\# \text{ of spaces}} = \$10,580$	$\frac{(\text{project cost} - \text{construction cost}) \times 100}{\text{construction cost}} = 13.3\%$	$\sqrt[t]{\text{cost } 2 / \text{cost } 1} - 1 = \text{escalation factor}$ $t = \text{number of years}$
$\frac{\$22,736,535}{2,149} = \$10,580$	$\frac{(\$29,900,000 - \$26,388,732) \times 100}{\$26,388,732} = 13.3\%$	$\sqrt[5]{15,066 / 10,580} - 1 = 7.3\%$
$\frac{\$22,689,514}{1,506} = \$15,066$	$\frac{(\$25,963,000 - \$22,689,514) \times 100}{\$22,689,514} = 14.4\%$	$\sqrt[5]{28,879 / 15,066} - 1 = 13.9\%$
$\frac{\$6,815,573}{236} = \$28,879$	$\frac{(\$12,336,023 - \$10,522,106) \times 100}{\$10,522,106} = 17.2\%$	

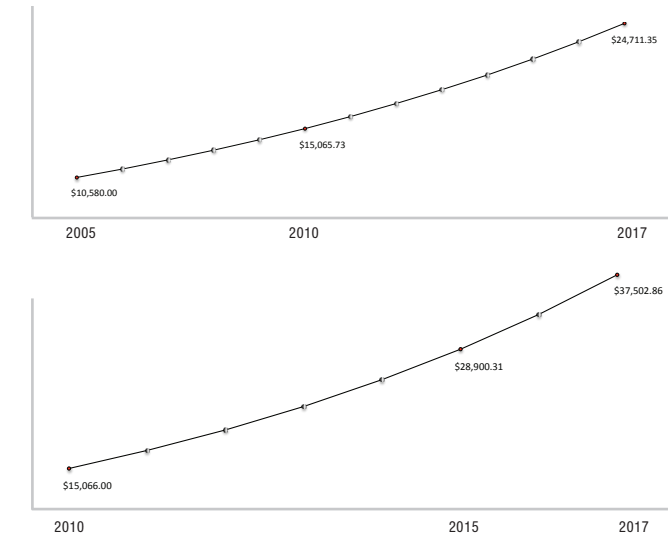

RESULTS

All options presented provide a range of increased parking for not only the NE corner of campus, but also the overall demand for the entire campus. Our study also shows that a structured parking garage coupled with a Gregg Avenue extension will result in significant traffic reduction along Maple Street as well as Leverett Avenue. Parking numbers provided by a proposed Douglas Street Garage are outlined in detail in the Matrix on pages 21 and 22. The approximate range of 1,200 to 2,400 spaces offers several options to consider for best fit. Traffic impact is diagrammed on page 49 while specific streetscape improvements are proposed and keynoted on the plan on page 50. Pages 51 and 52 summarize an analysis of comparable project data and present cost estimate information for each preferred option in this study.

An analysis of the project data for three comparable projects gives us known soft cost factors, cost per space data, and cost per space escalation percentages between projects. The soft cost factor (the percentage of increase from construction cost to project cost) was determined to range from 13% to 17%. The cost per space ranged from \$10,580 to \$28,879, and the escalation factor between the three projects shows a cost per space increased by 7.3% to 13% between projects. It should be stated that there are significant differences in each project that do not support a 1:1 comparison of the cost per space per project. Harmon Ave Parking Deck is the most efficient project and yields the best cost per space ratio due to the large number of parking spaces, while Spring St Parking Deck is the least efficient due to the very small number of spaces. Furthermore, from 2005 to 2010, the economic health of the construction environment experienced swings in stability, which would yield skewed data in years of economic decline.

ESCALATED COST CHART (ESCALATION FACTOR = 3% OVER 12 MONTHS)

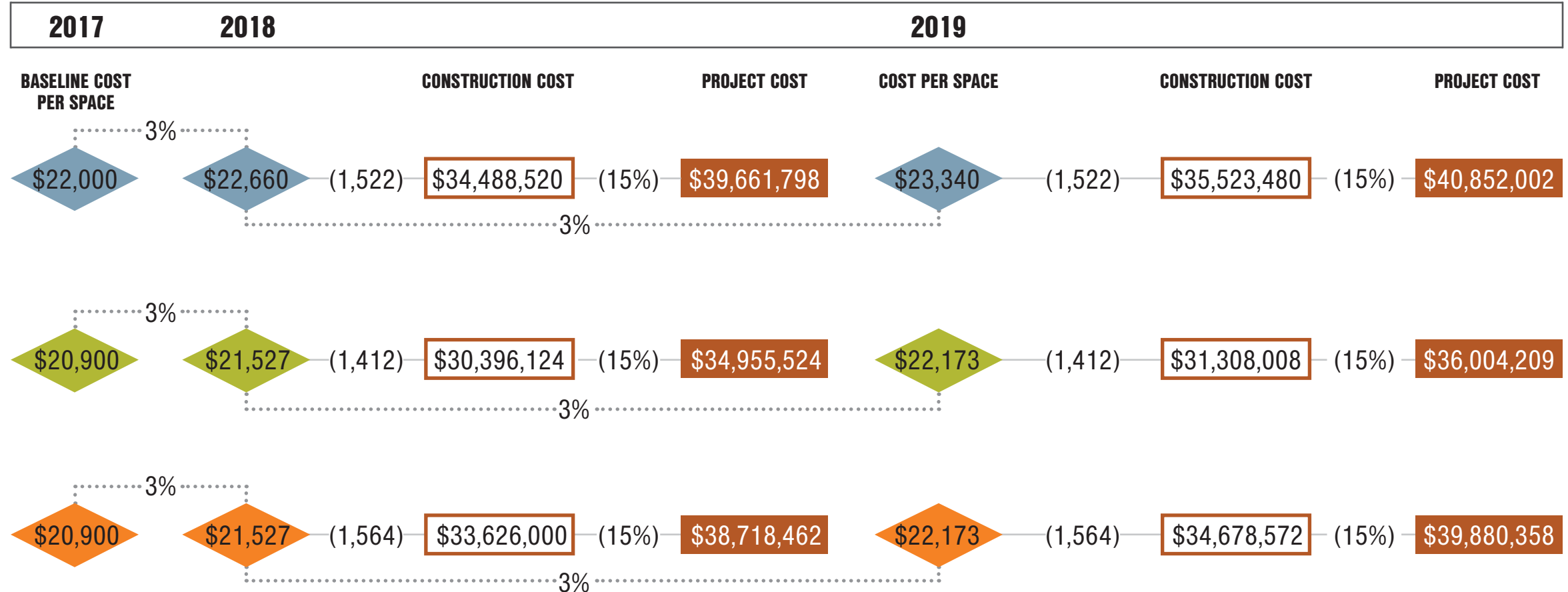

To inform our cost estimate exercise, we have taken into consideration the analysis of known project data. We are using the known soft cost factor of 13% to 17% to estimate our soft cost factor of 15%. However, when determining our estimated cost per space, we are basing our estimate on the project that was most similar to our presented options. - Garland Avenue Parking Deck. Based on a standard escalation factor of 3% per year, the known cost per space of \$15,066 in 2010 can be projected to \$19,085 to \$22,259, which matches construction costs specific to our region for the calendar year of 2017.

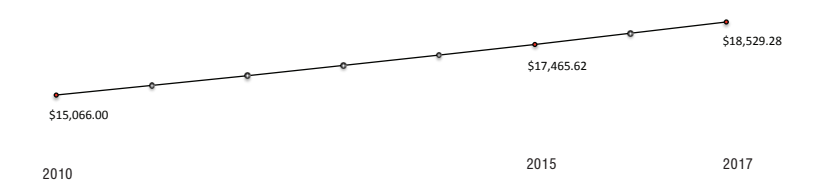

Our consensus is that we should use a baseline estimated cost of \$22,000¹ per parking space to determine the construction cost of each preferred option. This number takes into account a few assumptions. First, the garage would receive moderate architectural treatment around all open facades similar to what is normally seen in a campus setting. Second, the number is slightly higher than average due to the existing topography resulting in mass excavation and complicated retaining systems. We are holding a slightly lower number for scenarios that limit the amount of excavation by stepping the garage up the hillside (\$20,900 per space).²

Finally, the escalated cost chart attempts to project future costs for each preferred option (A.1, B.1, and C.1) by using a gradual increase of 3% based on the year construction commences.

DOUGLAS STREET GARAGE PLANNING STUDY

prepared for:
UNIVERSITY OF ARKANSAS | FAYETTEVILLE
FACILITIES MANAGEMENT PLANNING AND DESIGN

10.9.2017
v3.0

